



# DEVELOPMENT OF ISLANDING DETECTION ARRANGEMENT FOR GRID USING BAD VOLTAGE AND FREQUENCY SENSING

<sup>1</sup>Shital Shivaji Amale, <sup>2</sup>Shrutika Dilip Auti, <sup>3</sup>Shraddha Santosh Kanskar ,  
<sup>4</sup>Tanvi Vilas Gawas, <sup>5</sup>Maya Giri

<sup>1</sup>Bachelor of Engineering, Samarth College of Engineering and Management, Belhe  
<sup>2</sup>Bachelor of Engineering, Samarth College of Engineering and Management, Belhe  
<sup>3</sup>Bachelor of Engineering, Samarth College of Engineering and Management, Belhe  
<sup>4</sup>Bachelor of Engineering, Samarth College of Engineering and Management, Belhe  
<sup>5</sup>Asst. Prof. Electrical Dept. Samarth College of Engineering and Management, Belhe

## ABSTRACT

By identifying islanding circumstances in grid-connected dispersed generating systems, "Development of Islanding Detection Arrangement for Grid Using Bad Voltage and Frequency Sensing" aims to increase the security and dependability of electrical power networks. When a section of the electrical grid is cut off from the main utility grid but still receives electricity from nearby generation sources, this is known as islanding. If this situation is not identified promptly, it may result in equipment damage, safety risks, and problems with power quality. The suggested system continually monitors grid parameters and detects anomalous operating circumstances using voltage sensing and frequency sensing techniques. Real-time measurements of voltage levels and frequency fluctuations are made using sensors. The control circuit automatically identifies islanding when the measured values above predetermined safe limits. condition and disconnects the distributed generation source from the grid using protective relays. The system is designed using microcontroller-based monitoring and protection circuits to ensure fast and accurate operation. The arrangement improves the stability of the power distribution network and protects electrical equipment from faults caused by voltage fluctuations and frequency deviations. The proposed project can be applied in solar power systems, wind energy systems, smart grids, and other distributed energy applications to ensure safe and reliable grid operation.

**Keywords** - Islanding Detection, Grid Protection, Voltage Sensing, Frequency Sensing, Distributed Generation, Smart Grid, Protective Relay, Power System Safety, Renewable Energy System, Microcontroller, Grid Monitoring, Electrical Protection System.



## I. INTRODUCTION

Energy is essential to industrial progress, economic expansion, and scientific innovation. Because of its variety and significance in industries, transportation, communication, healthcare, and domestic uses, electrical energy is the most frequently used type of energy. The need for a steady and dependable source of power has increased dramatically as urbanization and industry have increased. To increase efficiency and dependability, modern power systems today incorporate cutting-edge technology including distributed generating sources, smart grids, microgrids, and intelligent monitoring systems. In recent years, there has been a dramatic rise in the integration of renewable energy sources, such as wind turbines and solar photovoltaic systems, into the electrical grid. Years Although distributed generation systems provide environmental and economic benefits, they also create operational challenges in power networks. One major issue is islanding, which occurs when a distributed generator continues supplying power to a section of the network even after disconnection from the main utility grid due to faults or maintenance activities. Islanding conditions can cause safety hazards, voltage instability, equipment damage, and difficulties in grid restoration. Therefore, effective islanding detection and protection schemes are essential to maintain grid stability, ensure operator safety, and improve the reliability of modern electrical power systems.

## II. OBJECTIVES

The creation of an islanding configuration based on

1. This project's primary goal is to provide an effective islanding detection system for grid-connected distributed generating systems.
2. To create a monitoring system that can detect poor voltage circumstances, such as overvoltage and undervoltage, continually.
3. The goal of this project is to improve the protection mechanism of distributed generation systems that are connected to the utility grid, such as solar photovoltaic and wind energy systems.
4. Improving safety for utility employees and energy users during islanding situations is a key goal of this project.
5. The goal of this project is to create an autonomous control system that can recognize and react to poor voltage and frequency conditions without the need for human interaction.

## III. SYSTEM OVERVIEW

The goal of the study "Developing an Islanding Arrangement for Grid on Sensing Bad Voltage/Bad Frequency" is to immediately disconnect the load or distributed generation system under dangerous operating circumstances by identifying abnormal voltage and frequency characteristics in a power grid. This enhances electrical safety, prevents islanding, and shields equipment from harm. The AC feed from the utility grid starts the system's operation. A transformer is used to first scale down the AC voltage since electronic circuits need low-voltage DC electricity. Additionally, the transformer offers

electrical isolation between the low-voltage control circuitry and the high-voltage grid. A rectifier then transforms the lower AC voltage into DC, which is subsequently controlled to give the electronic components a steady supply. the microcontroller to calculate the grid frequency accurately. Along with frequency monitoring, a voltage comparison circuit continuously checks whether the grid voltage remains within the permissible range. Any overvoltage or undervoltage condition generates a signal for further processing.

The microcontroller acts as the central control unit of the system. It receives inputs from the frequency monitoring circuit, voltage comparison circuit, and zero-crossing detector. These inputs are continuously analyzed and compared with predefined threshold values stored in the program memory. If the voltage or frequency exceeds the allowable limits, the microcontroller identifies the condition as a potential islanding fault. An LCD display provides real-time information such as voltage, frequency, and system status. Simultaneously, a buzzer generates an audible alarm to alert the operator about the fault condition. The microcontroller then controls a relay, which acts as an automatic switch. During normal operation, the relay keeps the load connected to the grid. However, when abnormal voltage or frequency is detected, the relay disconnects the load, preventing unsafe islanding operation and ensuring reliable protection for grid-connected systems.

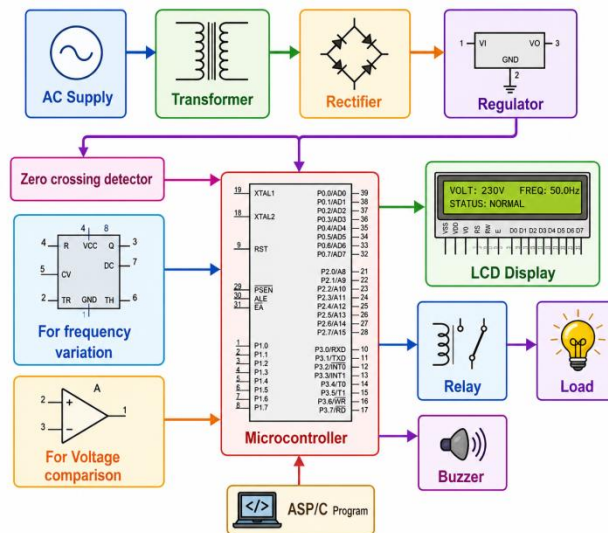

Fig.1- Proposed System

#### IV. HARDWARE COMPONENTS

- **Microcontroller IC**

One of the major advantages of the AT89C51 is its ability to support in-system programming. The program memory can be reprogrammed directly within the circuit without removing the microcontroller from the system. It can also be programmed using a conventional nonvolatile memory programmer. Due to its compact design, low power requirement, easy interfacing capability, and

reliable performance, the AT89C51 is extensively used in embedded control systems, automation projects, robotics, industrial monitoring systems, and power system protection applications. The microcontroller acts as the central control unit in the project “Developing an Islanding Arrangement for Grid on Sensing Bad Voltage/Bad Frequency.” Its main function is to continuously monitor the voltage and frequency conditions of the electrical grid and identify abnormal operating situations. The microcontroller receives input signals from the voltage comparison circuit, frequency sensing circuit, and zero crossing detector.



Fig.2- Arduino Uno (Microcontroller)

- **Zero crossing Detector IC**

A Zero Crossing Detector (ZCD) is an electronic circuit that identifies the points where an AC waveform crosses the zero voltage level, i.e., when the voltage changes its polarity from positive to negative or vice versa. In the context of islanding detection, the ZCD continuously monitors the AC mains voltage waveform. Each time the waveform crosses zero volts, the ZCD outputs a digital pulse or signal. The microcontroller or processing unit uses the timing of these pulses to calculate the AC supply's frequency. If the timing between zero crossings deviates beyond a preset threshold, indicating an abnormal frequency, the system flags a potential islanding or grid fault condition. Similarly, the zero-crossing information can be synchronized with voltage sampling to detect bad voltage conditions. Sudden shifts or missing zero crossings can also indicate grid disturbances or failures.



Fig.3- Zero Crossing Detector

- **Timer IC**

In the islanding detection system, the Timer IC, commonly the 555 Timer IC, plays an important role in generating accurate timing pulses and delays required for monitoring frequency variations and voltage stability in the electrical grid. The timer circuit helps the system measure the operating frequency precisely and assists the microcontroller in detecting abnormal grid conditions that may lead

to islanding situations. The 555 Timer IC is generally operated in monostable mode for this application. In monostable operation, the timer produces a single output pulse whenever it receives a triggering signal from the zero-crossing detector or another sensing circuit. The duration of the output pulse depends on the external resistor and capacitor connected to the timer circuit.



Fig.4- Timer IC

- **LM 385 Comparator**



Fig.5- LM 385 Comparator

The LM385 is a dual differential voltage comparator IC widely used in electronics for comparing two voltage levels. It outputs a digital signal indicating which input voltage is higher. Comparators like LM385 are essential in embedded systems for threshold detection, sensor interfacing, and safety applications. The LM385 comparator plays an important role in the project “Developing an Islanding Arrangement for Grid on Sensing Bad Voltage/Bad Frequency” by detecting abnormal voltage conditions in the electrical grid. The IC continuously compares the sensed grid voltage with a predefined reference voltage to identify overvoltage or undervoltage conditions. In the circuit, one input terminal of the LM385 receives the sensed voltage signal from the grid through a voltage divider network, while the other input receives a fixed reference voltage.

- **Transformer**

A transformer operates on the principle of Faraday’s Law of Electromagnetic Induction, which states: “When a changing magnetic flux links with a coil, an electromotive force (EMF) is induced in that coil.” In a transformer, alternating current (AC) in the primary winding produces an alternating magnetic flux in the core, which induces a voltage in the secondary winding. A transformer works by using electromagnetic induction to change voltage, based on its transformation ratio, which is the ratio of the number of turns in the secondary coil.  $K=V_2/V_1= E_2/E_1$

=  $\frac{N_2}{N_1}$  equals the fraction with numerator cap V sub 2 and denominator cap V sub 1 end-fraction equals the fraction with numerator cap E sub 2 and denominator cap E sub 1 end-fraction equals the fraction with numerator cap N sub 2 and denominator cap N sub 1 end-fraction.

- **Rectifier**

A rectifier is an electronic device that converts alternating current (AC) into direct current (DC). The working principle is based on the unidirectional conduction property of diodes they allow current to flow only in one direction (forward-biased) and block it in the other (reverse-biased). Principle: Rectification converting AC (bidirectional) to DC (unidirectional) using semiconductor diodes. In the Islanding system, the rectifier: Converts 230 V AC mains into 12 V AC (via transformer). Converts 12 V AC into 5 V regulated DC using the rectifier + filter + regulator combination. Provides a stable and safe DC power supply for the Arduino microcontroller, sensors, buzzers, and LED indicators. Without the rectifier, the Arduino and sensors could not operate since they require DC power.



Fig.6- Rectifier

- **Voltage Regulator**

A voltage regulator is an electronic circuit that maintains a constant output voltage regardless of changes in input voltage or load conditions. It works on the principle of feedback control: When the output voltage varies, the regulator adjusts its internal resistance or conduction so that the output remains steady. In this project, the IC 7805 (a fixed 5 V linear voltage regulator) is used to supply a constant 5 V DC to the Arduino, ultrasonic sensors, LEDs, and buzzer. The rectifier circuit converts 230 V AC → 12 V AC → 12 V DC (unregulated). The unregulated DC is applied to the input pin of the 7805 regulator. Inside the IC, the reference voltage and feedback network control the pass transistor so that the output remains fixed at 5 V, even if:

The input voltage fluctuates (within limits, typically 7 – 20 V), or The connected load (Arduino, sensors, LEDs) changes. The excess voltage is dropped across the pass transistor as heat, so the regulator may require a heat sink for high currents.



Fig.7- Voltage Regulator

- **Relay**

In a grid-connected system, islanding occurs when a distributed generator (DG) continues to supply power to a local load after the main utility grid has been disconnected. This can be dangerous because:

It poses a safety risk to utility workers.

It can damage equipment due to abnormal voltage or frequency.

It can cause protection issues in the grid.

Typical UV/OV & UF/OF relays used for islanding detection have the following specifications and Typical UV/OV and UF/OF relays used for islanding detection operate with preset voltage and frequency thresholds, fast response time, high sensitivity, reliable fault detection capability, and automatic disconnection during abnormal grid conditions.



Fig.8- Relay

## V. WORKING PRINCIPLE

The goal of the study "Developing an Islanding Arrangement for Grid on Sensing Bad Voltage/Bad Frequency" is to immediately disconnect the load if anomalous operating circumstances are recognized by continually monitoring grid voltage and frequency parameters. To guarantee accurate islanding detection and electrical safety, the system incorporates power supply circuits, sensor units, comparator circuits, a microprocessor, display modules, and protective devices. The process starts with a transformer (TR1), which provides electrical isolation while stepping down the 230V AC mains supply to a low-voltage AC level. The AC power is converted to DC by a bridge rectifier made of diodes, and the output is smoothed by filter capacitors. The voltage regulator IC7805 provides a stable

+5V DC supply for all electronic components. An LED indicates the availability of power. An AT89C51 microcontroller serves as the central controller of the system. A crystal oscillator generates a stable clock signal for accurate timing and processing. The LM393 comparator monitors grid voltage by comparing the sensed voltage with preset reference values adjusted using potentiometers. Any overvoltage or undervoltage condition generates a fault signal for the microcontroller.

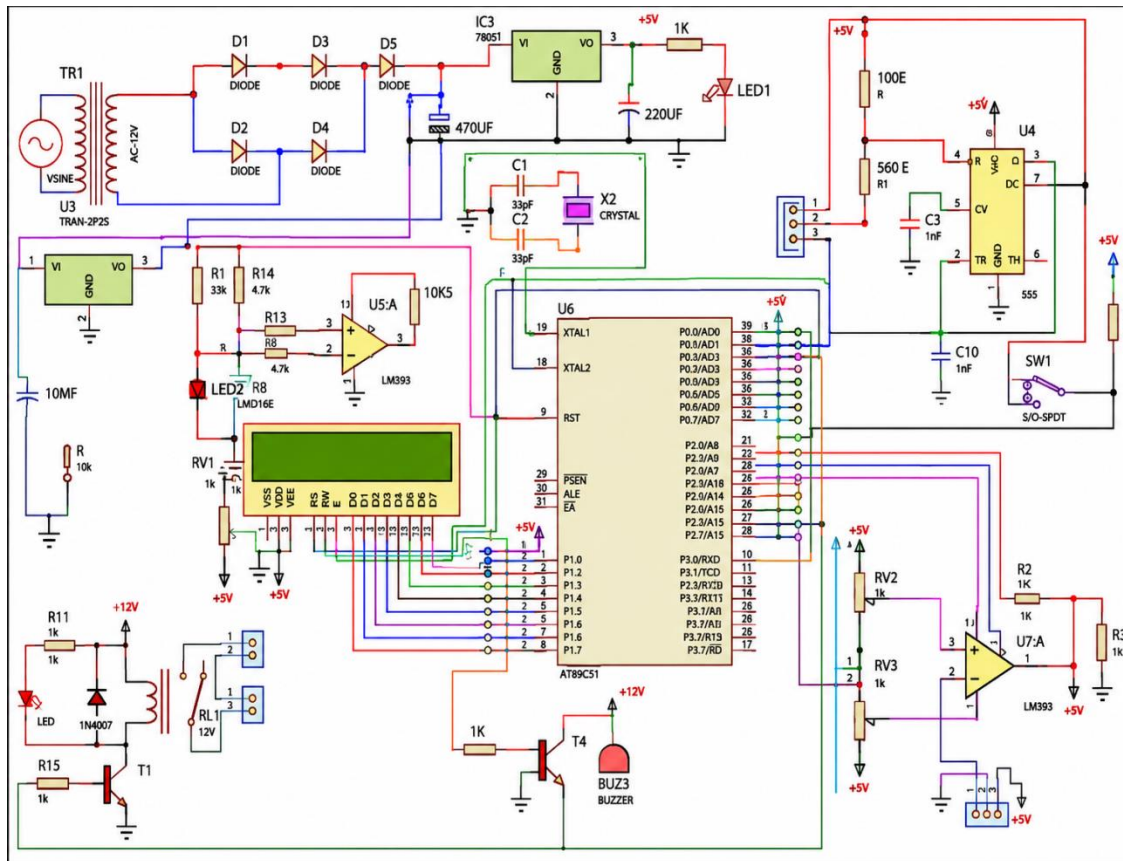

Fig.9- Circuit Diagram of the System

Frequency monitoring is performed using a 555 timer circuit that produces pulses corresponding to the grid frequency. The microcontroller measures these pulses and identifies abnormal frequency conditions. A 16×2 LCD displays voltage, frequency, and fault information in real time.

When abnormal voltage or frequency is detected, the microcontroller activates a transistor-driven relay to disconnect the load from the grid. Simultaneously, a buzzer provides an audible warning. Thus, the system offers automatic monitoring, rapid fault detection, reliable protection, and enhanced safety for grid connected systems.

## VI. RESULT AND DISCUSSION

Test No.	Test Condition	Input Action	Measured Frequency	Lamp	System Status
1	Normal Condition	Both pots mid + SW LEFT	<b>50Hz</b>	ON	Grid Healthy
2	Under Voltage	Op-Amp1 pot below 2.5V	X	OFF	Islanding
3	Over Voltage	Op-Amp2 pot above 2.5V	X	OFF	Islanding
4	Frequency Normal	SW RIGHT + 555 at 50Hz	<b>50 Hz</b>	ON	Grid Healthy
5	Bad Frequency Low	SW RIGHT + 555 pot high resistance	<b>35Hz</b>	OFF	Islanding
6	Bad Frequency Low	SW RIGHT + 555 pot high resistance	<b>42Hz</b>	OFF	Islanding

The experimental findings show how well the Islanding Arrangement for Grid on Sensing Bad Voltage/Bad Frequency works under different circumstances. The relay remained powered, the light remained on, and the LCD showed normal system status during normal operation when voltage thresholds were appropriately set and frequency was kept at 50 Hz. The comparator circuits identified voltage variations from the predetermined reference level and transmitted fault signals to the microcontroller for undervoltage and overvoltage checks. In order to preserve the equipment, the controller promptly disabled the relay, removed the load, and reported an islanding status. A 555 timer circuit was used for frequency testing. The system functioned properly at the typical frequency of 50 Hz with the relay ON and the load connected. However, when abnormal frequencies of 35Hz, 42Hz, and 80Hz were generated, the microcontroller detected the fault conditions and tripped the relay. The lamp turned OFF, indicating successful load isolation. These results confirm accurate voltage and frequency monitoring, rapid fault detection, reliable islanding protection, and improved safety for grid-connected systems.

## VII. EXPERIMENTAL SETUP

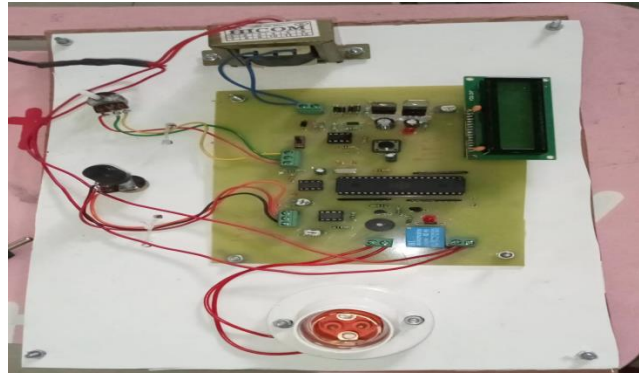

Fig.10- Experimental Setup

## VIII. CONCLUSION

The effective design and implementation of the article "Developing an Islanding Arrangement for Grid on Sensing Bad Voltage/Bad Frequency" offers dependable protection for distributed generation networks and grid-connected electrical systems. The designed system successfully identifies anomalous operating circumstances by continually monitoring the utility grid's voltage and frequency parameters. The configuration offers precise islanding detection and prompt protective response through the use of voltage sensor circuits, frequency detection units, comparators, timer circuits, and a microcontroller-based control system. Under various fault scenarios, including overvoltage, undervoltage, overfrequency, and underfrequency, the suggested system functions effectively. The microprocessor instantly initiates the relay mechanism to cut off the load from the utility grid if the detected voltage or frequency beyond the specified safe operating limits.

## REFERENCES

- [1].Mohamadreza Hashemi, Hamidreza Mahdian & Ali Asghar Ghadimi, "A New Method for Islanding Detection the Grid Connected Inverters in Case of Unbalanced Loads," Indian Journal of Science and Technology, 2013.
- [2]. A. Sai Subhadra, P. Linga Reddy & Shailesh B. Modi, "Islanding Detection in a Distribution System with Photovoltaic (PV) System as Distributed Generation," Indian Journal of Science and Technology, 2015.
- [3]. Riyasat Azim, Fangxing Li, Yaosuo Xue, Michael Starke & Honggang Wang, "An Islanding Detection Methodology Combining Decision Trees and Sandia Frequency Shift for Inverter-Based Distributed Generations," IET Generation, Transmission & Distribution, 2017.
- [4]. Muhammad Al Azis Bachrun, Eka Firmansyah & Muhammad Isnaeni Bambang Setyonegoro, "A Review of Various Frequency Drift Based Islanding Detection Methods," International Journal of Engineering Research & Technology (IJERT), 2017.



- [5]. John Sundar D. & Senthil Kumaran M., “A Comparative Review of Islanding Detection Schemes in Distributed Generation Systems,” International Journal of Renewable Energy Research (IJRER), (year not clearly given).
- [6]. Mehdi Hosseinzadeh & Farzad Rajaei Salmasi, “Islanding Fault Detection in Microgrids—A Survey,” Energies, 2020.
- [7].M. Krishna Goriparthi & B. Geetha Lakshmi, “Balanced Islanding Detection of Distributed Generator using Discrete Wavelet Transform and Artificial Neural Network,” International Journal of Engineering Trends and Technology (IJETT), 2021.
- [8]. Jie Dong & Ya Jun Rong, “Research on Islanding Detection for Grid-Connected Inverter and Protection Criterion Based on Fuzzy Clustering Analysis,” Advanced Materials Research, Vol. 383-390, 2012.
- [9]. Sunanda E., Divya Spandana S. & Ganapaneni Swapna, “Islanding Detection for Grid Connected Photo-Voltaic Systems for Excess Generation and Under Generation,” International Journal of Engineering and Technology (IJET), 2018.
- [10] Naima Ikken, Nour-Eddine Tariba, Abdelhadi Bouknadel, Ahmed Haddou, Hafsa El Omari & Hamid El Omari, “A Fuzzy Rule Based Approach for Islanding Detection in Grid Connected Inverter Systems,” International Journal of Electrical and Computer Engineering (IJECE), 2021.