



THE AUTOMATIC CLIMATE CLOCK AND NOTIFIER SYSTEM DIGITAL

¹Pawan Prakash Gaykar, ²Kanav Bhausahab Aglave, ³Pratik Bhanudas Kapse, ⁴Altamash Munir Shaikh, ⁵Pathan A.S., ⁶Mr. Tribhuvan S.B.

¹UG Scholar, Mechatronics Dept. Samarth Polytechnic, Belhe

²UG Scholar, Mechatronics Dept. Samarth Polytechnic, Belhe

³UG Scholar, Mechatronics Dept. Samarth Polytechnic, Belhe

⁴UG Scholar, Mechatronics Dept. Samarth Polytechnic, Belhe

⁵Lecturer, Mechatronics Dept. Samarth Polytechnic, Belhe

⁶HOD Mechatronics Dept. Samarth Polytechnic, Belhe

ABSTRACT- The Automatic Climate Clock and Notifier System Digital is a sophisticated electronic system that uses a digital display to provide current clock data, environmental conditions, and critical alerts. To create an intelligent and automated information system, the system combines a microprocessor, wireless communication module, climate sensors, real-time clock module, and LED display panel. Temperature and humidity sensors continually monitor ambient conditions, and the real-time clock guarantees precise timekeeping. Users may submit notifications via a mobile device and have them quickly shown on the digital screen thanks to the wireless connection capability. This technology increases the effectiveness of communication in public spaces, offices, hospitals, and schools while reducing manual labor. The vivid LED screen offer high visibility and ensures that messages can be easily read from a distance. The system is energy-efficient, cost-effective, and easy to install. It also supports real-time monitoring and automated notifications, making it suitable for modern smart environments. The Automatic Climate Clock and Notifier System Digital enhance convenience, improves information delivery, and supports smart automation. Future improvements can include IoT connectivity and advanced environmental monitoring features to expand system capabilities.

Keywords- Automatic Climate Clock, Digital Notifier System, Arduino, LED Display, Temperature Monitoring, Humidity Sensor, Real-Time Clock, Wireless Communication, Smart Display System, Embedded System.

I. INTRODUCTION

The Automatic Climate Clock and Notifier System Digital is a sophisticated electronic information system that uses a digital LED display to show the current time, environmental conditions, and customized notification messages. This system creates a contemporary solution for residences, workplaces, educational institutions, and public areas by combining wireless connectivity, time tracking, and intelligent control features. This project's main goal is to deliver precise time updates,



climate-related data, and crucial alerts in an understandable and effective digital format. The central processing unit of the system is a microcontroller-based platform. It gathers information from several modules, processes it, and presents relevant material. Wireless message sending using a mobile phone is made possible by a Bluetooth communication module.

application. This wireless communication feature eliminates the need for manual input devices and allows users to update notifications instantly from a convenient distance. Messages such as announcements, reminders, alerts, and event information can be easily transmitted and displayed in real time.

A Real-Time Clock module plays a crucial role in maintaining accurate time. This module continues to track time even during power interruptions with the help of its backup battery. The microcontroller retrieves the time data from the clock module and displays it continuously. This ensures that the system functions as a reliable digital clock with high precision and stability. Along with time display, the system can be programmed to show scheduled notifications at specific intervals, making it useful for reminders and automated alerts.

II. OBJECTIVES

- To keep an eye on humidity and temperature
- To Show Current Climate Data
- To Send Out Notification Alerts
- To Create a Monitoring System Based on Clocks
- To Minimize Human Effort

III. SYSTEM OVERVIEW

The Automatic climatic Clock and Notifier System Digital is a sophisticated environmental monitoring system that shows the current climatic conditions, time, and alert messages. A mobile phone with Bluetooth software, a Bluetooth module (HC-05), an Arduino controller, a Real Time Clock (RTC) module, a P10 LED display, and a power supply section are all integrated into the system. This project's primary goals are to use a digital display to track environmental conditions, show the time, and send out message notifications. In order to accomplish effective climate monitoring and alerting, the block diagram shows how each component interacts with the others.

In this system, the mobile phone with a Bluetooth application acts as a user interface. The user can send messages or commands using the mobile application. These commands are transmitted wirelessly through Bluetooth communication. The Bluetooth technology provides short-range wireless communication, making the system convenient and easy to operate. When the user sends a message from the mobile phone, the data is transmitted to the Bluetooth module HC-05. This module receives the wireless signal and converts it into serial communication data that can be processed by the controller.

The Bluetooth module HC-05 plays an important role in communication. It acts as a bridge between the mobile phone and the Arduino controller. The module communicates with the Arduino using serial communication through TX and RX pins. When the Bluetooth module receives the message from the mobile phone, it sends the data to the Arduino controller. The Arduino processes the received data and prepares it for display on the P10 LED display.

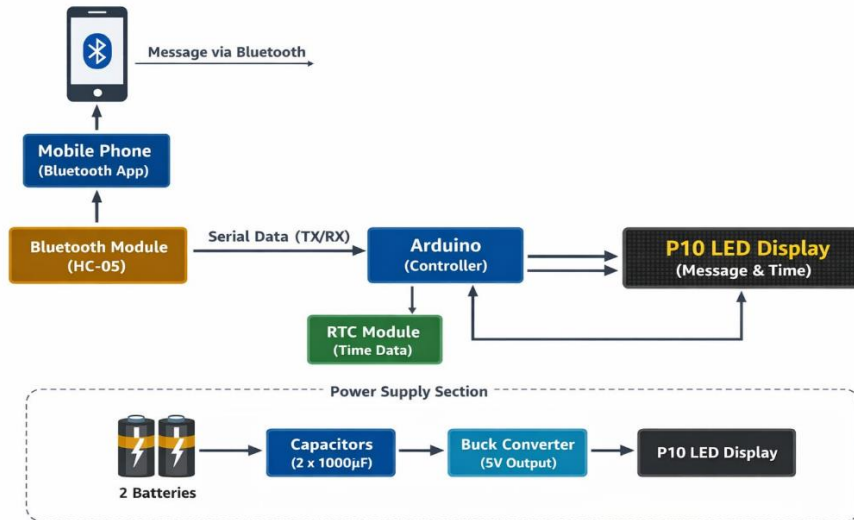

Fig.1- System Design

The Automatic Climate Clock and Notifier System Digital uses an Arduino controller as the central processing unit to manage all system operations. The Arduino receives messages from the Bluetooth module and time data from the RTC module, then controls the P10 LED display to show scrolling messages and time information. The RTC module maintains accurate time using a crystal oscillator and backup battery, ensuring continuous operation even during power failure. The P10 LED display acts as the output unit, showing time, notifications, and climate-related information with high brightness and visibility.

The power supply section provides stable voltage using batteries, capacitors, and a buck converter to regulate the output to 5V. When a user sends a message through a mobile phone, the Bluetooth module transfers it to the Arduino. The controller processes the message and time data, then displays it on the LED panel. This system offers wireless communication, accurate timekeeping, easy message updates, and improved efficiency.

IV. HARDWARE COMPONENTS

- **Arduino Uno**

The Arduino Uno plays a central role in the Automatic Climate Clock and Notifier System Digital. It acts as the main control unit that manages all system operations including climate monitoring, clock synchronization, message processing, and display control. The Arduino Uno receives input data from sensors, Bluetooth module, and RTC module, processes the information, and sends output signals to the P10 LED display. The microcontroller ensures that all components

communicate properly and work in a synchronized manner. This makes the Arduino Uno the brain of the entire system. The working of the Arduino Uno begins when power is supplied to the board through a regulated 5V power supply. Once powered, the microcontroller initializes all connected modules such as RTC, display, and communication interfaces. The Arduino continuously reads time data from the RTC module using I2C communication protocol. At the same time, it receives climate data from temperature and humidity sensors. The Arduino processes this data and formats it into readable text. The formatted data is then sent to the P10 LED display to show time, temperature, humidity, and notification messages.

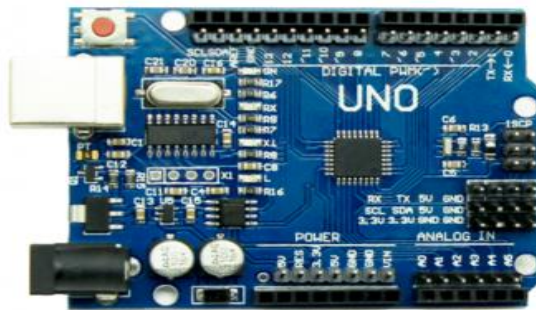

Fig.2- Arduino Uno

The Arduino Uno also controls display timing and brightness. It generates clock signals and control signals required by the P10 LED display. The microcontroller sends row selection signals, data signals, and latch signals to the LED display. This enables smooth scrolling and stable display output. The Arduino also ensures that updates occur without flickering or delay, providing a clear and readable display. Technical specifications of Arduino Uno used in the system include the ATmega328P microcontroller with 16 MHz clock frequency.

- **Bluetooth Module HC-05**

The HC-05 Bluetooth Module plays an important role in the Automatic Climate Clock and Notifier System Digital by enabling wireless communication between the mobile phone and the controller unit. The Bluetooth module allows users to send notification messages, update system parameters, and control display information without using physical connections. This wireless communication improves flexibility, ease of operation, and user convenience in the system. The working of the Bluetooth module begins when power is supplied to the circuit. The module enters pairing mode and waits for connection from a smartphone or other Bluetooth-enabled device. The user opens a mobile application and connects to the Bluetooth module using its default name and password. Once paired, the mobile device sends data such as notification messages, climate settings, or display commands. The Bluetooth module receives this data wirelessly and converts it into serial communication signals. These signals are then transmitted to the Arduino controller through UART communication pins.



Fig.3- Bluetooth Module HC-05

- **RTC Module**

The DS3231 RTC Module plays an important role in the Automatic Climate Clock and Notifier System Digital by providing accurate time and date information. The RTC (Real Time Clock) module maintains time continuously and ensures that the system displays correct clock information along with climate data and notification messages. The RTC module operates independently of the main controller and continues to track time even when the main power supply is turned off. This feature makes it highly reliable for clock-based monitoring applications.

The working of the RTC module begins when power is supplied to the system. The RTC module uses a crystal oscillator to maintain accurate time counting. It continuously counts seconds, minutes, hours, days, months, and years. The module is connected to the controller using I2C communication protocol through SDA and SCL pins. The controller sends commands to the RTC module and reads the current time data. The received time information is then processed and displayed on the P10 LED display along with climate information and notification messages.



Fig.4- RTC Module

- **Buck Converter**

The DC-DC Buck Converter plays an important role in the Automatic Climate Clock and Notifier System Digital by providing regulated and stable voltage to all electronic components. The

buck converter is used to step down a higher input voltage to a lower output voltage suitable for components such as Arduino Uno, Bluetooth module, RTC module, and P10 LED display. This voltage regulation is necessary because different components require stable 5V DC power for proper operation. The buck converter improves efficiency and reduces power loss compared to linear voltage regulators. The working of the buck converter is based on switching regulator technology. When input voltage is supplied from batteries or external power supply, the buck converter reduces the voltage using high-frequency switching components such as MOSFETs, inductors, capacitors, and control circuits.



Fig.5- Buck Converter

- **Capacitor**

The Capacitor plays an important role in the Automatic Climate Clock and Notifier System Digital by stabilizing the power supply and filtering unwanted noise from the circuit. Capacitors are mainly used in the power supply section to smooth voltage fluctuations and provide stable DC voltage to sensitive components such as the Arduino controller, Bluetooth module, RTC module, and P10 LED display. A stable power supply is essential for proper system performance and accurate operation of all modules.

The working of the capacitor is based on its ability to store electrical energy in the form of an electric field. When power is supplied to the circuit, the capacitor charges and stores energy. When voltage drops or fluctuations occur, the capacitor releases stored energy to maintain stable voltage. This charging and discharging process helps reduce ripple voltage and noise in the power supply. In the Automatic Climate Clock and Notifier System Digital, capacitors are placed across the power supply lines to filter unwanted AC components from DC supply. This ensures smooth and reliable operation of the system.

V. WORKING PRINCIPLE

A microprocessor, real-time clock module, temperature sensors, wireless communication module, and LED display are all integrated into the Automatic temperature Clock and Notifier System Digital. Data is gathered from several modules, processed by the controller, and displayed in real time as part of the system's operation. The Arduino microcontroller serves as the focal point for all operations and

component communication management. When all components are powered on, the system starts to function. The Real-Time Clock (RTC) module uses a backup battery and an internal crystal oscillator to continually maintain precise time and date information. This time data is read by the Arduino, which then gets it ready for display. Climate sensors, including temperature and humidity sensors, simultaneously track

The Bluetooth module enables wireless communication between the mobile phone and the system. When the user sends a message through a mobile application, the Bluetooth module receives the message and transfers it to the Arduino. The controller processes the received message and combines it with time and climate data.

After processing, the Arduino sends the information to the P10 LED display. The display shows scrolling messages, current time, and climate information. The system continuously updates the data, allowing real-time monitoring and message display. The power supply unit ensures stable voltage to all components, ensuring reliable performance. This integrated working principle allows the system to function as an automatic clock, climate monitor, and digital notification system.

Circuit Diagram:

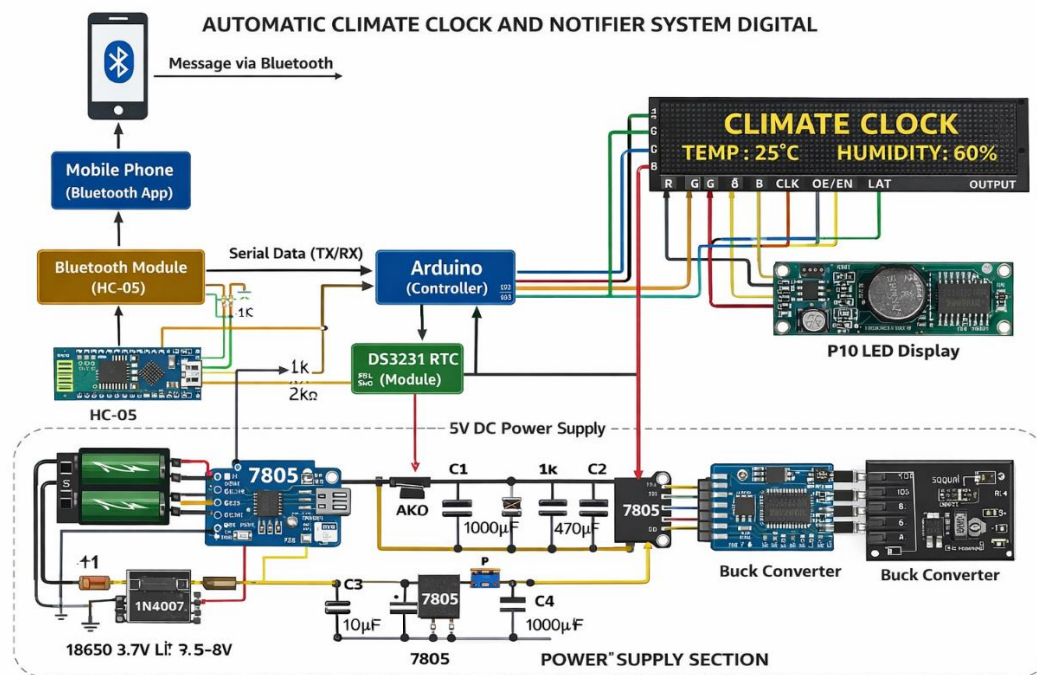

Fig. 6- Circuit Diagram

The circuit diagram of the Automatic Climate Clock and Notifier System Digital is designed to display real-time climate information, clock data, and notification messages using a P10 LED display. The system consists of major blocks including the mobile phone with Bluetooth application, HC-05 Bluetooth module, Arduino controller, RTC module, P10 LED display, and power supply section. Each block is interconnected to ensure smooth communication, accurate timekeeping, and stable power distribution. The overall circuit is designed on a PCB layout to reduce wiring complexity, improve reliability, and enhance system performance.

The mobile phone acts as the user interface of the system and is used to send messages or configuration commands through a Bluetooth application. The mobile device transmits wireless data using Bluetooth communication protocol operating at 2.4 GHz frequency band. The user can send customized messages, update system settings, and control display functions directly from the smartphone. The mobile application communicates wirelessly with the HC-05 Bluetooth module, which receives the transmitted data and forwards it to the microcontroller for processing.

- **Flow Chart of the System:**

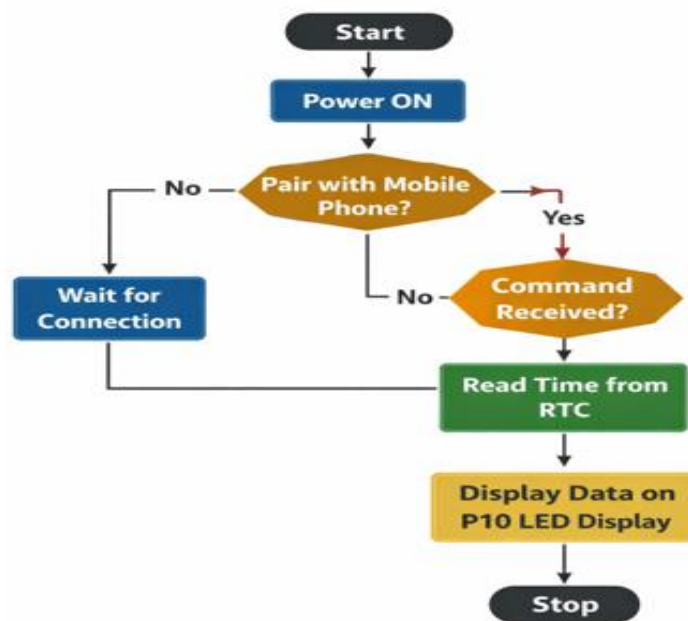

Fig.7- Flow Chart of the proposed system

The flow chart of the Automatic Climate Clock and Notifier System Digital explains the step-by-step working of the system using a Yes/No decision-making process. The operation begins with system initialization, where all components such as the Arduino controller, Bluetooth module, RTC module, and LED display are activated. After power is supplied, the system checks whether the voltage is stable. If stable, the system proceeds; otherwise, it waits until proper voltage is achieved. Next, the system checks whether the Bluetooth module is paired with a mobile phone. If not, it waits for connection. Once connected, the system checks whether a command is received. If no command is received, the system displays default information such as time and climate data. If a command is received, the controller processes the message and reads accurate time from the RTC module. Finally, the processed data is displayed on the P10 LED display as scrolling messages and clock information. The system continuously repeats this cycle for real-time operation.

- **Experimental Set up**

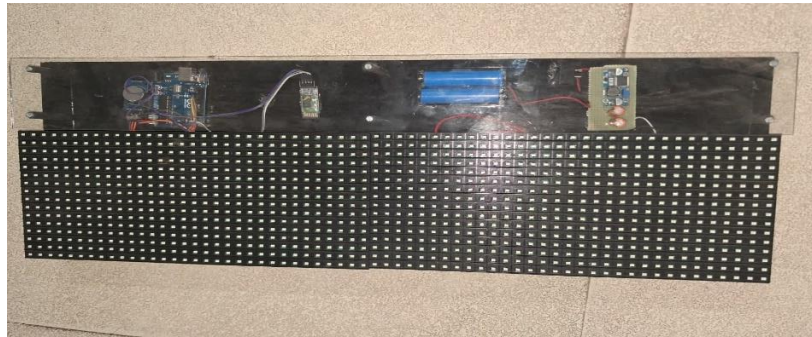

Fig.8- Experimental Set up

VI. RESULT AND DISCUSSION

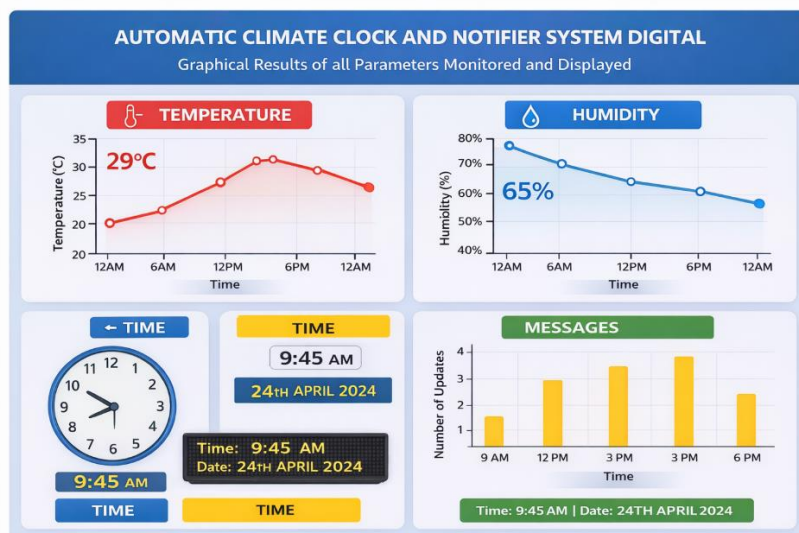

Fig.9- Result Analysis

The Automatic Climate Clock and Notifier System Digital is a smart display system that tracks temperature, humidity, time, and message alerts. The temperature graph displays daily fluctuations, beginning at midnight at around 20°C, increasing to about 31°C in the afternoon, and falling by night. The humidity graph shows that values are greater around midnight, between 75% and 78%, then progressively decrease to 60% to 65% throughout the day. Both analog and digital clock displays that provide precise time and date are included in the time parameter. To provide effective communication and real-time monitoring, the message parameter shows the frequency of notifications, which increases during business hours and decreases in the evening.

VII. CONCLUSION

A cutting-edge and effective solution, the Automatic climatic Clock and Notifier System Digital shows current time, climatic data, and critical alerts in a single integrated system. This project creates an intelligent and user-friendly information system by combining digital display technologies, wireless connectivity, and microcontroller-based automation. By automating the process of updating messages and showing precise time and environmental data, the system successfully minimizes



manual labor. The device also aids in maintaining suitable environmental conditions in a variety of places by incorporating climate monitoring elements like temperature and humidity. The deployment of wireless communication, which enables users to send notifications straight from a cell phone, is one of the project's greatest accomplishments. This feature increases adaptability and guarantees

quick updates without requiring physical access to the display. The use of a real-time clock module ensures accurate timekeeping even during power interruptions, making the system reliable and efficient.

REFERENCES

1. V. V. Praveen Kumar, Vutukuri Sai Mounika, Bandaru Gayathri, Yelchuri Venkata Sudheshna, Kaki Sandhya, and Gogulapati Glory presented the paper titled "IoT Enabled Real-Time Digital Campus Notice Board" in the International Journal of Engineering Research and Science & Technology in 2024.
2. Rajeshwari S., Ushasree R., and Fong Kim C. published the paper "Digital Notice Board using Bluetooth and Arduino" in INTI Journal in 2024.
3. R. Robert, N. Akilan, S. Naveen Kumar, C. Pon Sekar, and G. Santhosh presented "IoT Based Digital Notice Board Using Arduino" in the International Journal of Scientific Research in Science, Engineering and Technology in 2021.
4. Kian Layague published "Arduino-Based Temperature and Humidity Sensor for Classroom Monitoring and Hydration Reminder" in the International Journal of Educational Technology Research in 2023.
5. Paul Kamweru, Owino Ochieng Robinson, and Mutinda Mutava Gabriel presented "Monitoring Temperature and Humidity using Arduino Nano and DHT11 Sensor" in the International Journal of Engineering Research in 2020.
6. Anas Tukur Balarabe and Zahriya Lawal Hassan published "Arduino UNO Based Environment Monitoring System" in IOSR Journal of Electronics and Communication Engineering in 2019.
7. S. Sumathi and R. Uthirasamy presented "Smart Phone Integrated Wireless LED Notice Board" in the International Journal of Advanced Science and Engineering in 2024.
8. S. V. Balshetwar, Rutuja Pise, Sakshi Devkule, Mansi Yadav, and Aniket Shirke published "Arduino Based Wireless Digital Notification Board" in the Journal of Data Engineering and Knowledge Discovery in 2023.
9. V. Siva Nagaraju, Panjala Charansai, Kaparavena Bhargavaram, and Apuri Chathurya presented "IoT Based Weather Monitoring System using Arduino UNO" in the International Journal of Engineering Research and Technology in 2024.
10. N. S. Hemalatha and Dr. P. Santhanalakshmi presented "Wireless Electronic Notice Board System using IoT" in the International Advanced Research Journal in Science Engineering and Technology in 2024.
11. S. Kumar and R. Patel presented "Smart Digital Notice Board using Arduino" at the IEEE International Conference on Smart Systems in 2018.