

INTERNET OF THINGS (IOT) BASED SMART ENERGY MANAGEMENT SYSTEM FOR RENEWABLE ENERGY INTEGRATION

¹Sakshi Arun Kotkar, ²Gayatri Kailas Mitke, ³Gayatri Raju Satalkar, ⁴Meghna Parasram Thakare, ⁵Dr. P.C. Tapre, ⁶Dr.Sanjay Kumar

¹UG Scholar, Electrical Dept. SND College of Engineering and Research Center, Yeola, Nashik.
²UG Scholar, Electrical Dept. SND College of Engineering and Research Center, Yeola, Nashik,
³UG Scholar, Electrical Dept. SND College of Engineering and Research Center, Yeola, Nashik,
⁴UG Scholar, Electrical Dept. SND College of Engineering and Research Center, Yeola, Nashik,
⁵Asst. Prof. Electrical Dept. SND College of Engineering and Research Center, Yeola, Nashik
⁶Asst. Prof. Electrical Dept. SND College of Engineering and Research Center, Yeola, Nashik

ABSTRACT - The use and efficacy of Internet of Things (IoT)-based smart energy management systems in residential and business settings are examined in this study. The research explores how IoT technologies contribute to energy conservation through real-time monitoring, automated control systems, and data-driven decision making. Over a 24-month period from January 2022 to December 2023, information was gathered from 50 residential structures and 15 business establishments. IoT-based energy management systems decreased overall energy usage by an average of 23% in residential buildings and 31% in commercial facilities, according to the report. The design of IoT-based systems, implementation difficulties, and potential future paths for this field's advancement are all further examined in this paper.

Index Terms - Internet of Things, Energy Management, Smart Buildings, Energy Efficiency, Machine Learning, Cloud Computing.

I. INTRODUCTION

1.1 General

The paper layout uses a microcontroller approach to automatically pick supplies from solar and wind. One source with alternate switches is supplied to provide the same purpose since it is not practical to provide all four separate sources of supply. We regard the two switches in this project to be two distinct supply sources. Pressing any of the switches indicates that the source that is linked to the microcontroller as input signals is not present. Microcontrollers from the 8051 series are used here. The ULN2803, which functions as a relay driver, receives the microcontroller's output. Up to seven relays can be driven by this. These relays are 12V relays.

converted to DC using a Bridge rectifier. The ripples are removed using a capacitive filter and it is then regulated to +5V using a voltage regulator 7805 which is required for the operation of the

microcontroller and other components. Automating feature is now the need of the day. It is user friendly and easy to use. It saves time too. This project is also a proto-type to automation of the system. In the earlier days (even today at some places) the manual operations are frequent. In case of the electrical appliance control using automation causes more safety. This project is a prototype for the same which is auto change over to solar when wind supply fails. In this system we are designing an embedded circuit to control this. In case there are four phases, then the switching will be in the default phase. Four relays are there to control the switching. The phases will be shown by the operation of switch that is on /off. According to the conventional model of current flow originally established by Benjamin Franklin and still followed by most engineers today, current is assumed to flow through electrical conductors from the positive to the negative pole. In actuality, free electrons in a conductor nearly always flow from the negative to the positive pole. In the vast majority of applications, however, the actual direction of current flow is irrelevant. Therefore, in the discussion below the conventional model is retained. Terminal to the right along the red (positive) path to the output, and returns to the lower supply terminal via the blue (negative) path. In each case, the upper right output remains positive and lower right output negative. Since this is true whether the input is AC or DC, this circuit not only produces a DC output from an AC input, it can also provide what is sometimes called "reverse polarity protection". The phases will shown by the operation of switch that is on /off.

1.2 Objectives

- Design supply monitoring circuit
- Design of relay switching assembly

1.3 Limitations:

- Relatively complex than existing systems.
- Switching losses are relatively higher

II. LITRATURE SURVEY

1*Sudha Yelmareddy,*G Mahesh,*K Anitha Reddy,*A Vinod Kumar, “Auto Power Supply Control from Four Different Sources” Auto supply switching is basically selection of supply from multiple available power sources automatically by using microcontroller concept that is to check the availability of the source and switching to that available source to ensure uninterrupted power supply to load. In case of the electrical appliance control using automation causes more safety. Auto supply switching is a prototype for the same which is auto change to other source when main supply fails without human interaction in this system we are designing an embedded circuit to control and ensure auto supply switching. In case all 4 phases are available, then the switching will be in the default phase. Four relays are there to control the switching. As it is not feasible to provide all 4 different sources of supply, one source with

alternate switches are provided to get the same function. In this project we are having 4 switches which we consider as 4 different source of supply. When we press any of the switches it shows the absence of that particular source which is connected to microcontroller as input signals. Here we are using Atmega 328p family microcontroller. The output of microcontroller is given to the ULN2003 this acts as a relay driver. The current phase working is displayed on LCD also.

2*Mr.Shahaji Dudhate, *Mr.Amol Attargekar, *Mr.Dhanaji Desai, *Prof. Mrs.Aditi Patil, “Power Supply Control from Different Sources” The main purpose of this project is to provide continuous power supply to a load, by selecting the supply from any of the four sources namely solar, inverter, main and generator automatically in case if one the source is absent. The need of electricity is increasing day by day and the frequent power cuts of electricity are causing many problems in different areas like banks, colleges/schools, hospitals, houses and industries. Thus there is requirement for an alternate arrangement of power supply. This arrangement can be designed by using ARM7 microcontroller and relays. When a source, say mains fails the supply automatically shifts to next priority source generator and so on. LEDs (Light emitting diodes) can be used to show that which source is used to provide the supply.

3*Jenyfal Sampson *G. Arunsai Kumar, *C. Balaji Dileep, *G. Vinay Kumar, *B. Venkata Kiran, “Auto power supply control from three different sources” The main aim in designing our project is to provide continuous power supply for the load with the three different sources (Mains, Solar, Generator). No person is needed to pick any available source to supply to load. During this system, the AC mains is employed continuously as supply to the load, if by some cause AC mains power supply fails then load gets supply from Solar. We are using generator as third option of power supply to take care of continuous power supply. When three sources are failed to supply the power to the load then we will get intimated by buzzer.

III. METHODOLOGY

3.1 Block diagram

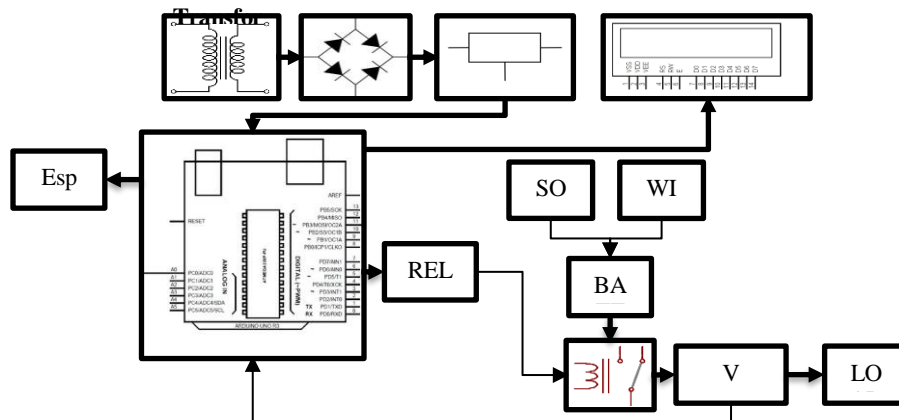

Fig 1- Block diagram for relay switching with controller for different power supply

3.2 Circuit diagram

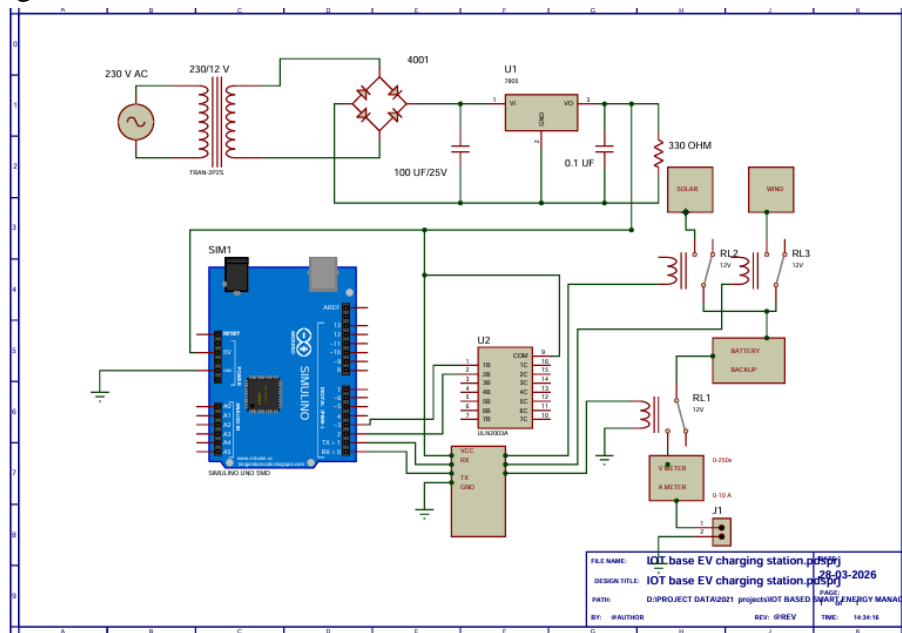

Fig 2- Circuit diagram of auto power switching

3.3 Working

In order to control our project, we provide a 328p microcontroller in this article. The relay is used to switch the power source management based on the controller's signal. The microcontroller is the project's brain. The power source is represented by switches whose on/off states indicate whether the power source is available or not. The microcontroller receives this signal and is programmed to meet the aforementioned specifications. The relay receives the microcontroller's output. In the end, the relay chooses the ac voltage phase. All other sources are turned off and only the solar power source is turned on if solar power is available. Choose a different priority source if solar power is not available.

IV. HARDWARE AND SOFTWARE

4.1 Arduino board

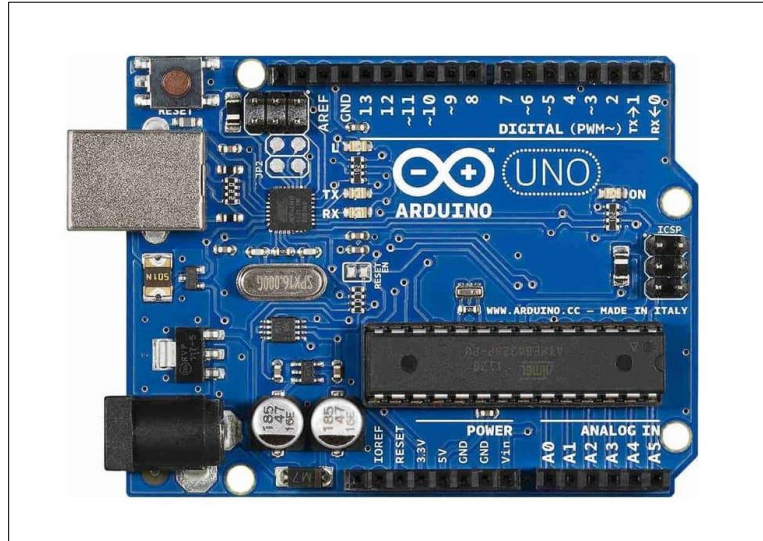

The Arduino Uno is a microcontroller board based on the ATmega328 (datasheet). It has 14 digital input/output pins (of which 6 can be used as PWM outputs), 6 analog inputs, a 16 MHz crystal oscillator, a USB connection, a power jack, an ICSP header, and a reset button. It contains everything needed to support the microcontroller; simply connect it to a computer with a USB cable or power it with a AC-to-DC adapter or battery to get started. The Uno differs from all preceding boards in that it does not use the FTDI USB-to-serial driver chip. Instead, it features the Atmega8U2 programmed as a USB-to-serial converter. "Uno" means one in Italian and is named to mark the upcoming release of Arduino 1.0. The Uno and version 1.0 will be the reference versions of Arduino, moving forward. The Uno is the latest in a series of USB Arduino boards, and the reference model for the Arduino platform; for a comparison with previous versions, see the index of Arduino boards,

4.2 Power

The Arduino Uno is a microcontroller board based on the ATmega328 (datasheet). It has 14 digital input/output pins (of which 6 can be used as PWM outputs), 6 analog inputs, a 16 MHz crystal oscillator, a USB connection, a power jack, an ICSP header, and a reset button. It contains everything needed to support the microcontroller; simply connect it to a computer with a USB cable or power it with a AC-to-DC adapter or battery to get started. The Uno differs from all preceding boards in that it does not use the FTDI USB-to-serial driver chip. Instead, it features the Atmega8U2 programmed as a USB-to-serial converter. "Uno" means one in Italian and is named to mark the upcoming release of Arduino 1.0. The Uno and version 1.0 will be the reference versions of Arduino, moving forward. The Uno is the latest in a series of USB Arduino boards, and the

reference model for the Arduino platform; for a comparison with previous versions, see the index of Arduino boards.

4.3 Micro-controller unit

The heart of the whole project is the Micro-controller unit. For this project the Arduino Uno Micro-controller was used. It is a low power general purpose microcontroller with good processing speed, small physical dimension, that is durable and cheap

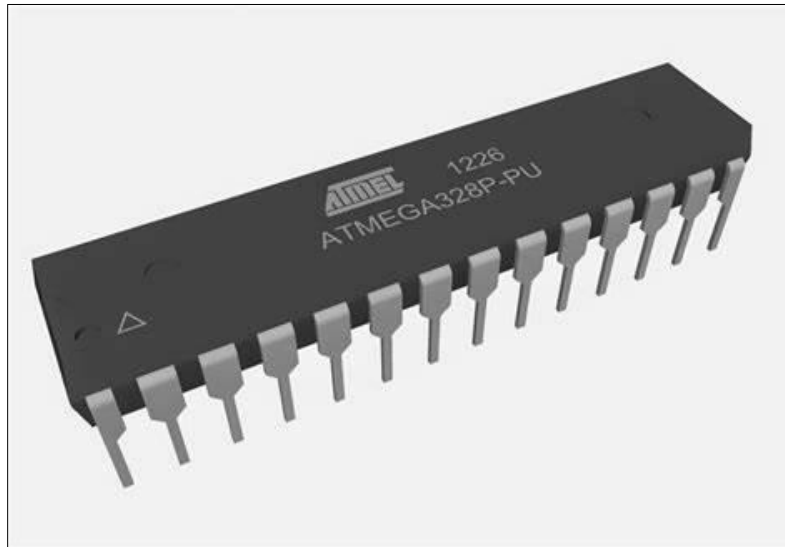

Fig 3(a): Atmega 328p

Summary

Microcontroller ATmega328 Operating Voltage 5V Input Voltage (recommended) 7-12V Input Voltage (limits) 6-20V Digital I/O Pins 14 (of which 6 provide PWM output) Analog Input Pins 6 DC Current per I/O Pin 40 mA DC Current for 3.3V Pin 50 mA Flash Memory 32 KB (ATmega328) of which 0.5 KB used by bootloader SRAM 2 KB (ATmega328) EEPROM 1 KB (ATmega328) Clock Speed 16MHz.

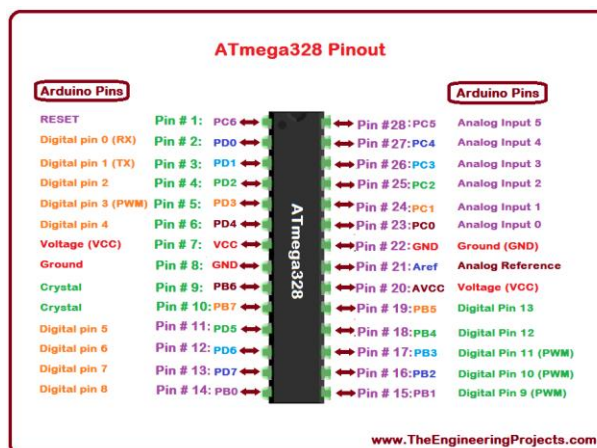

Fig 3(b): Pin diagram of Arduino uno Micro-controller

The Arduino Uno Micro-controller is interfaced with the RC522 Reader and DS3231 real –time clock module as inputs and the SD card module and both buzzer and led indicators as outputs. Each pin on the arduino micro-controller can supply 20mA each with 20 pins which gives a total of 400mA maximum current draw from the micro-controller, but it is not recommended to load the micro-controller to its maximum.

- **VIN.** The input voltage to the Arduino board when it's using an external power source (as opposed to 5 volts from the USB connection or other regulated power source). You can supply voltage through this pin, or, if supplying voltage via the power jack, access it through this pin.
- **5V.** This pin outputs a regulated 5V from the regulator on the board. The board can be supplied with power either from the DC power jack (7 - 12V), the USB connector (5V), or the VIN pin of the board (7- 12V). Supplying voltage via the 5V or 3.3V pins bypasses the regulator, and can damage your board. We don't advise it.
- **3V3.** A 3.3 volt supply generated by the on-board regulator. Maximum current draw is 50 mA.
- **GND.** Ground pins. Memory The ATmega328 has 32 KB (with 0.5 KB used for the bootloader). It also has 2 KB of SRAM and 1 KB of EEPROM (which can be read and written with the EEPROM library).

4.4 LCD(16x2)

Liquid crystal display (LCD) which has been used is 2x16 LCD. I.e. two lines each with 16 characters. The LCD has been used in 8bit mode i.e. 8 data lines are required. Other than 8 data line one RS, one RW & one enable line is also required. The RS line is used to select whether the data or instruction is being transferred between the controller and the LCD. The RW line is used to indicate if data is read from the LCD or written into the LCD. The RW pin is pulled low when data is being sent to the LCD. The enable pin is basically a latch pin which tells the LCD that the data is available on the data lines. The resistor R7 is used to set the intensity of the BACKLIGHT.

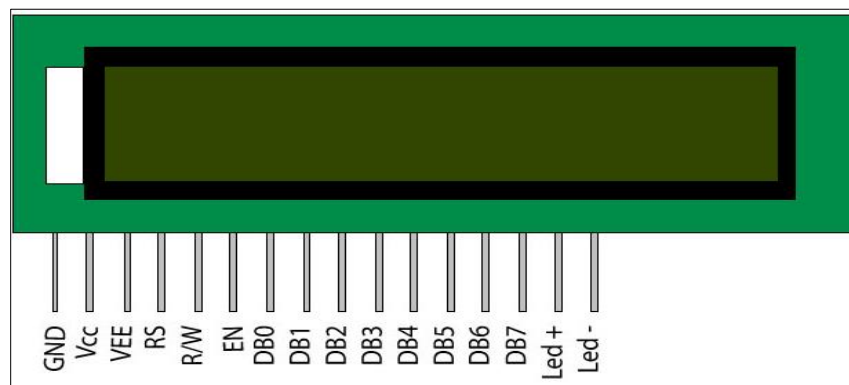
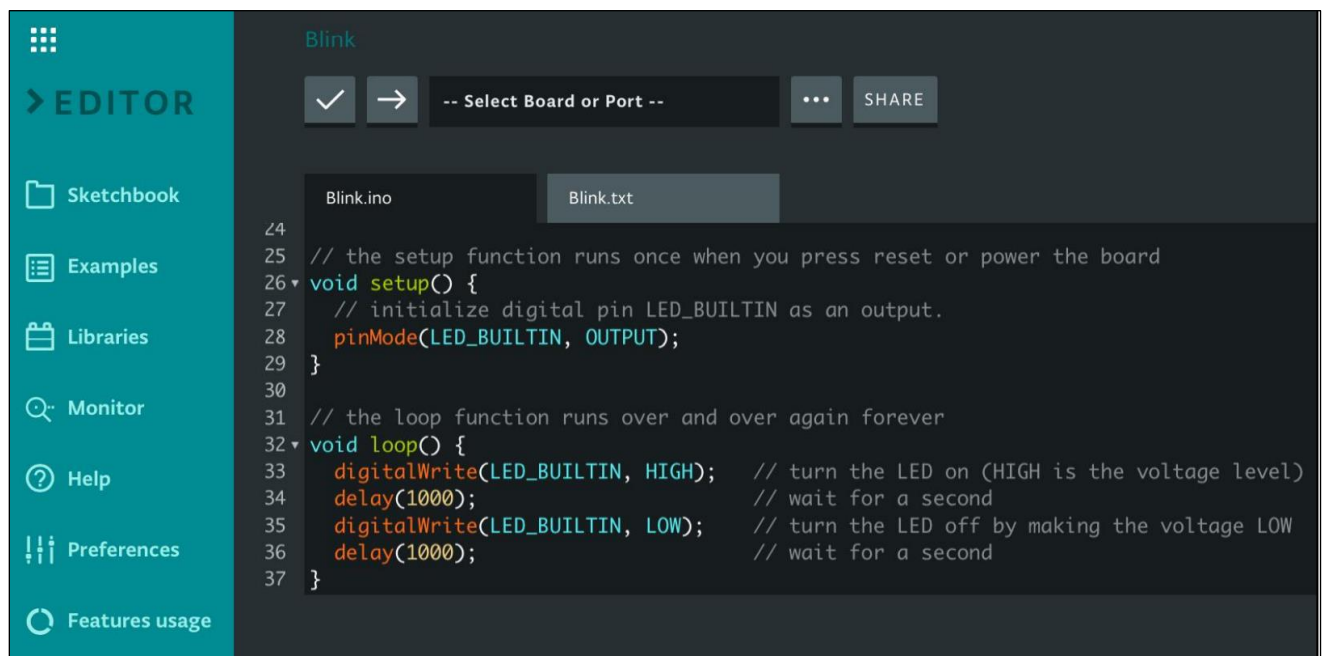
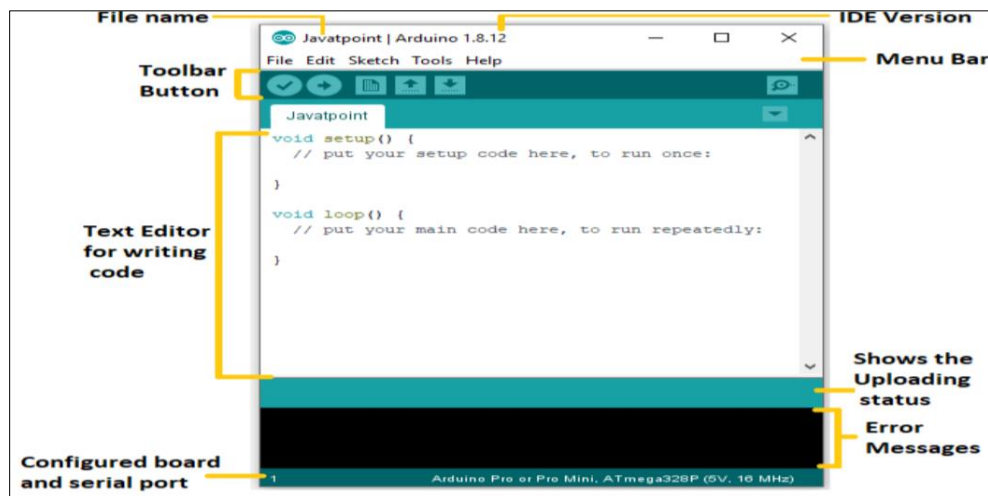

Fig.4: LCD display

4.5 SOFTWARE USED

4.5.1 ARDUINO IDE

The open-source Arduino Software (IDE) makes it easy to write code and upload it to the board. It runs on Windows, Mac OS X, and Linux. The environment is written in Java and based on Processing and other open-source software. This software can be used with any Arduino board



Refer to the Getting Started page for Installation instructions:



[1]. The Arduino Integrated Development Environment (IDE) is a cross-platform application (for Windows, macOS, Linux) that is written in functions from C and C++

[2]. It is used to write and upload programs to Arduino compatible boards, but also, with the help of 3rd party cores, other vendor development boards.

[3] The source code for the IDE is released under the GNU General Public License, version. [4] The Arduino IDE supports the languages C and C++ using special rules of code structuring.

[5] The Arduino IDE supplies a software library from the Wiring project, which provides many common input and output procedures. User-written code only requires two basic functions, for starting the sketch and the main program loop, that are compiled and linked with a program stub main () into an executable cyclic executive program with the GNU tool chain, also included with the IDE distribution.

[6] The Arduino IDE employs the program avrdude to convert the executable code into a text file in hexadecimal encoding that is loaded into the Arduino board by a loader program in the board's firmware.

[7] By default, avrdude is used as the uploading tool to flash the user code onto official Arduino boards

[8]Arduino Pro IDE:

| | |
|------------------|---|
| Developer(s) | : Arduino Software |
| Preview release | : v0.0.2 / 28 October 2019; 4 months ago |
| Repository | : github.com/arduino/Arduino |
| Written in | : C, C++ |
| Operating system | : Windows, macOS, Linux |
| Platform | : IA-32, x86-64, |
| ARM Type | : Integrated development environment |
| License | : LGPL or GPL license |
| Website | : blog.arduino.cc/2019/10/18/arduino-pro-ide-alpha-preview-with-advanced-features/ |

In October 2019 the Arduino organization began providing early access to a new Arduino Pro IDE with debugging and other advanced features.

4.6 PROTEUS 8.1

The Proteus is an electronic circuit design software which includes a schematic capture, simulation and PCB (Printed Circuit Board) Layout modules. But generally now a days Eagle CAD is highly preferred over Proteus for PCB designing because of its flexibility. Even though if u is not using for PCB designing u can view the PCB layout of the component individually while selecting the component it helps during the soldering of components in PCB. Proteus is ahead in simulating the circuits containing the micro controllers where we can simulate the circuit by uploading the hex code to the Micro-controller where as Mutism can't do this. Netlist file (Written in Verilog Code) if needed for your usage can also be extracted from the tools option in this software

V. ADVANTAGES, DISADVANTAGES AND APPLICATION

Advantages

- Uninterrupted power
- Continuity of opration
- Save time
- Smarty monitor the system operation

Disadvantages

- Relatively complex than existing systems.
- Switching losses are relatively higher

Application

- Use in industry
- Commercial complex, hospitals
- Inverter system in residential

VI. CONCLUSION

This study shows that both residential and business applications may profit greatly from IoT-based smart energy management systems. Significant energy savings are possible while preserving or enhancing occupant comfort because to the integration of automated controls, data analytics, and linked sensors. According to our research, well-executed systems may cut energy use by 23–31% in a variety of building types, with matching savings in running expenses and environmental effect. Even if there are still issues with initial costs, technical complexity, and compatibility, the value proposition is getting better thanks to continuous technology breakthroughs and declining hardware costs. In the upcoming years, performance and adoption rates should be substantially improved by the transition to more intelligent, integrated, and user-friendly systems. As environmental concerns grow and the world's energy needs continue to climb

REFERENCES

1. G. Mahesh , A.Vinod Kumar , K. Anitha Reddy and Y.Sudha, “Auto Power Supply Control from Four Different Sources,” Journal of Research in Science, Technology, Engineering and Management (JoRSTEM), ISSN: 2456-0197- February 2021.
2. Uneet Kumar Singh, “Automatic Phase Changeover Switch,” International Journal of Engineering Trends and Technology (IJETT) – Volume 34 Number2- April 2016.
3. Mr.Shahaji Dudhate, Mr.Amol Attargekar, Mr.Dhanaji Desai, Prof. Mrs.Aditi Patil, “Power Supply Control from Different Sources,” International Journal of Scientific & Engineering Research, Volume 7, Issue 1, January-2016.
4. Abdurrahman Shuaibu, Ibrahim Adabara, Kaumba Muteba, “Design and Implementation of an Automatic Power Supply from Four Different Source Using Microcontroller,” International Journal of Electrical and Electronic Science, ISSN: 2375-2998-2017
5. B Bhargava Reddy, D Sivakrishna and A V Sudhakara Reddy “Modelling and Analysis of Wind Power Generation Using PID Controller”, International Journal For Scientific Research & Development (IJSRD), Vol.1, No.9, pp.2045-2049, November 2013.
6. P Prasad, B Bhargava Reddy and A V Sudhakara Reddy “Power Loss Minimization in Distribution System using Network Reconfiguration with Particle Swarm Optimization”, International Journal of Engineering Science & Advanced Technology (IJESAT), Vol.5, Iss.3, pp.171-178, May 2015.
7. K.Surekha and A.V.Sudhakara Reddy “A New Control Topology for Smart Power Grids using Bi-directional Synchronous VSC”, International Journal of Informative & Futuristic Research, Vol.2, No.10, PP.3695-3704, June 2015.
8. A. V. Sudhakara Reddy, Prof. M. Damodar Reddy, “Optimization of Distribution Network Reconfiguration Using Dragonfly Algorithm”, Journal of Electrical Engineering, Vol.16, No.4, No.30, pp.273-282, 2017
9. A. V. Sudhakara Reddy, Dr. M. Damodar Reddy, “Network Reconfiguration of Distribution System for maximum loss reduction using Sine Cosine Algorithm”, International Journal of Engineering Research and Applications (IJERA), Vol.7, No.10, pp.34-39, October 2017.
10. A. V. Sudhakara Reddy, Dr. M. Damodar Reddy, “Optimal Capacitor allocation for the reconfigured Network using Ant Lion Optimization algorithm”, International Journal of Applied Engineering Research (IJAER), ISSN:0973-4562, Vol.12, No.12, pp.3084-3089, July 2017.
11. A. V. Sudhakara Reddy, M. Damodar Reddy and Y. V. Krishna Reddy “Feeder Reconfiguration of Distribution Systems for Loss Reduction and Emissions Reduction using MVO Algorithm”, Majlesi Journal of Electrical Engineering, Vol.12, No.2, pp.1-8, June 2018., pp.41-45, May 2017.