



SOLAR TRACKING SYSTEM

¹Prathamesh Appaso Molawade , ²Janmejyraje Yuvraj Bhosale, ³Someshsingh Anilsingh Jadon,
⁴Rahul Vishwanath Kshirsagar. ⁵Pratik Balaji Kamble, ⁶ J. S. Shaikh

¹UG Scholar, Electrical Dept. JSPM's Bhivrabai Sawant polytechnic, Wagholi

²UG Scholar, Electrical Dept. JSPM's Bhivrabai Sawant polytechnic, Wagholi

³UG Scholar, Electrical Dept. JSPM's Bhivrabai Sawant polytechnic, Wagholi

⁴UG Scholar, Electrical Dept. JSPM's Bhivrabai Sawant polytechnic, Wagholi

⁵UG Scholar, Electrical Dept. JSPM's Bhivrabai Sawant polytechnic, Wagholi

⁶Asst. Prof. Electrical Dept. JSPM's Bhivrabai Sawant polytechnic, Wagholi

ABSTRACT: The biggest challenge for the coming centuries is the generation of power from fossil fuels. Thus, the world has been inclined towards the use of renewable resources. The idea of the generation of electric energy from solar energy using photovoltaic panels has increasing importance. But the frequent change in the positions of the sun with respect to Earth is responsible for the loss of huge amounts of energy. Thus, it is necessary that the panel should continuously track the positions of the sun and thus it gives rise to the idea of sun-tracking solar panel systems. Sun-tracking solar panels will increase the panel's efficiency as it will be able to adjust its orientation with respect to the sun's position. The complete process of developing such panels, as well as how the system functions and other elements, are presented in this article. LDR sensors are used in the Arduino Nano-designed tracking system to measure sunlight intensity. The panel is rotated by the servo motor. As a result, the single-axis panels' orientation changes from east to west based on the sun's location.

keyword - Panels, Trackers, Sunlight, Intensity, Arduino, LDR sensors, Servo Motor.

I. INTRODUCTION

Approximately 28% of the world's power is generated by renewable energy sources. In the upcoming years, the need for electricity generation will only grow. Nevertheless, non-renewable resources, such as coal, oil, and gasses, are running out. One of the most potent sources for electricity creation is solar energy.. In the last decades, most of the residential areas installed solar systems. Thus, to utilize the efficiency of solar energy, the idea solar tracking system is proposed. The solar energy produced, largely depends upon the placement and orientation of the panel. To enhance the output obtained, the panel must be perpendicular to the sun throughout the day. As in the existing system. Sun tracking solar panel is a project which aims at designing a model in which the solar panel is self-orienting with respect to the positions of the sun in the sky. The innovation in this phenomenon is that, it generates more amount of power from solar energy than fixed systems in a lesser area. In fixed systems, to produce more power the panels of larger areas are required to be installed, but in this case, more amount of energy is generated while keeping the area of the panel the same. Thus, this method is most cost-effective as well as contributes to the proper utilization of energy.



II. LITERATURE REVIEW

In the past, research was made to solve the issue of loss of energy by solar panels. This paper suggests that the efficiency of solar power systems can be increased by incorporating a tracking system. Various types of tracking systems are possible. This paper is an overview of designing a single-axis sun tracker using a microcontroller. According to the study, these tracking technologies significantly boost energy production. Microcontrollers allow for more efficient manipulation of the system's operation. The variables that impact solar cell performance, including temperature, maximum power point tracking, and energy conversion efficiency, are discussed in this work. Solar cells are more efficient in various applications if all these factors are optimized. Thus, to utilize these factors a tracking system based on the function of a DC motor controlled by light sensors is fabricated. The tracking system is designed using a microcontroller as well as a servo motor.

The system can be programmed to rotate at different angles and also the sensitivity of the system can be encouraged by the use of Light Depending Resistors that is LDR sensors. This gives greater flexibility over existing systems. The paper explores how the single-axis algorithm could be extended to the dual-axis as well. This paper proposes a financial assessment of the economic benefits of tracking systems over traditional systems. The average cost and operating expenditures of sun trackers, as well as the energy market rate in Texas, served as the basis for the financial survey. The final result showed an overall improvement of almost 82%. As a result, the trackers turned out to be more advantageous financially. The comparison of tracking panels and fixed panel PV systems with the same rate powers in a year is the goal of this work. The installation took place in Florida. The Factors such as the annual power production by each array and the amount of CO₂ emission

Reduction suggested that the tracker system should be adopted and more research should be carried out in this aspect. The paper relates to the architecture of a simple dual-axis tracking system using Arduino and a stepper motor. It gives the algorithm of the relation between the working of a motor based on the signals received from LDR which are responsible for the moment of the solar panel.

This paper approaches a photovoltaic panel system using an Arduino-based application as monitoring media. The Android application monitors the temperature changes and conveys the necessary angle inputs. The node MCU is the communication bridge for the microcontroller. The system is commanded by open loop control system. Servo motors are attached to bike wheels which move solar panels to follow the sun's positions. Thus, the output from the mobile application which serves as input for the servo motor and the position of the panel is adjusted

The tracking systems designed using microcontrollers are efficient as they provide systematic working of the system. The LDR sensors used with appropriate arrangement provide the signals to the servo motor and thus the panel rotates with the desired angle according to the position perpendicular to the sun rays. The paper performs a techno-economic-environmental analysis of maximum power generation by the solar tracking system. The panels were installed in the residential areas. The results reflected that, by using tracking systems the number of plants needed was reduced. The single-axis tracking system resulted in greater cost-efficiency with 0.243 \$/kWh cost of energy with an average of 25% increase in the output power. Although the dual-axis tracker increased power generation by 33%, it was less cost-effective. The paper directs to the design of a dual-axis solar tracker. The panel adjusts its orientation by moving simultaneously in two directions. It is a closed-loop system using the Wheatstone bridge circuit that works with light-dependent resistors (LDRs).

III. METHADODOLOGY

3.1 Component used:

3.1.1 Hardware Requirements:

Solar Panel, LDR sensors, Arduino nano, LEDs, Servo Motor SG90, Cell 9V Resistor, Connecting-wires, Zero PCB, Foam Board

3.1.2 Software Requirements:

Arduino IDE for Program, Protius 8 for Circuit design.

3.2 Block Diagram:

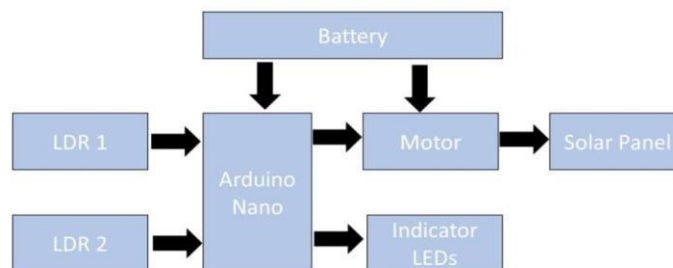
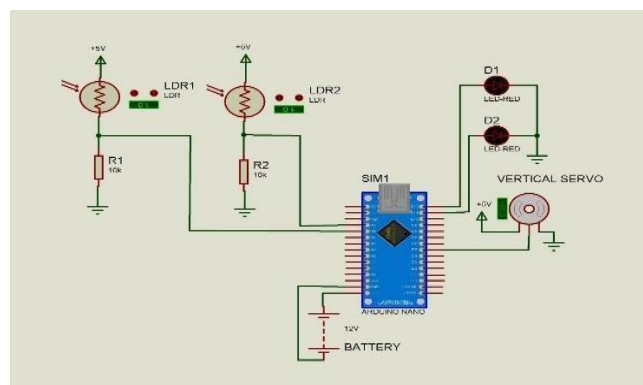

Fig. 1 Block diagram representing the flow of work of the project.



3.3 Working:

The circuit diagram showing how the project operates is shown above. A solar tracking system prototype is being built along the horizontal axis. An Arduino nano board and servo motor are used in the solar tracking system's circuit design to regulate the solar panel's position. Light-dependent resistors are used to track the position of the sun and to start the operation. This system is controlled with an SG90 servo motor. The single-axis solar tracking system is implemented here. Whenever the sunlight is incident on the LDR sensors the signals are sent to the servo motor through the microcontroller. Thus, The direction of rotation of the LDR is perpendicular to the first one. On the panel's side are two of these LDRs. Each of the two LDRs is separated from the other because of the partition between them. The resistance decreases as the amount of light falling on the LDR sensor rises.

Once more, resistors are connected in series with the two sensors. As a result, when the sun moves, the amount of sunlight that strikes the LDR setup varies as well because of the barrier. The voltage drop is formed at the junction of the LDR and the resistor. This voltage drop is passed as the input to the microcontroller. The servo motor spins at the required angle after receiving the digital signals, which causes the panel to revolve in the direction of highest intensity. As a result, it spins at a speed of around 15 degrees each hour.. Hence, a delay of 1.5 minutes is required. Because of this algorithm, sunlight radiating from every direction is tracked and the orientation of the panel is achieved.

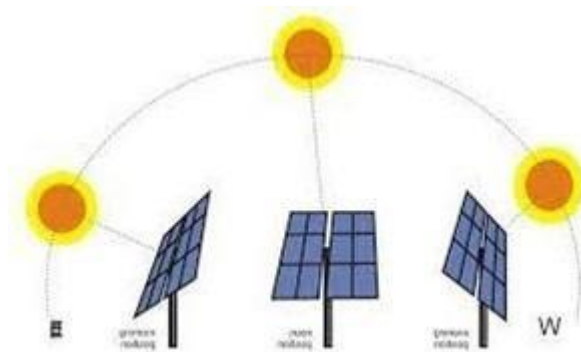
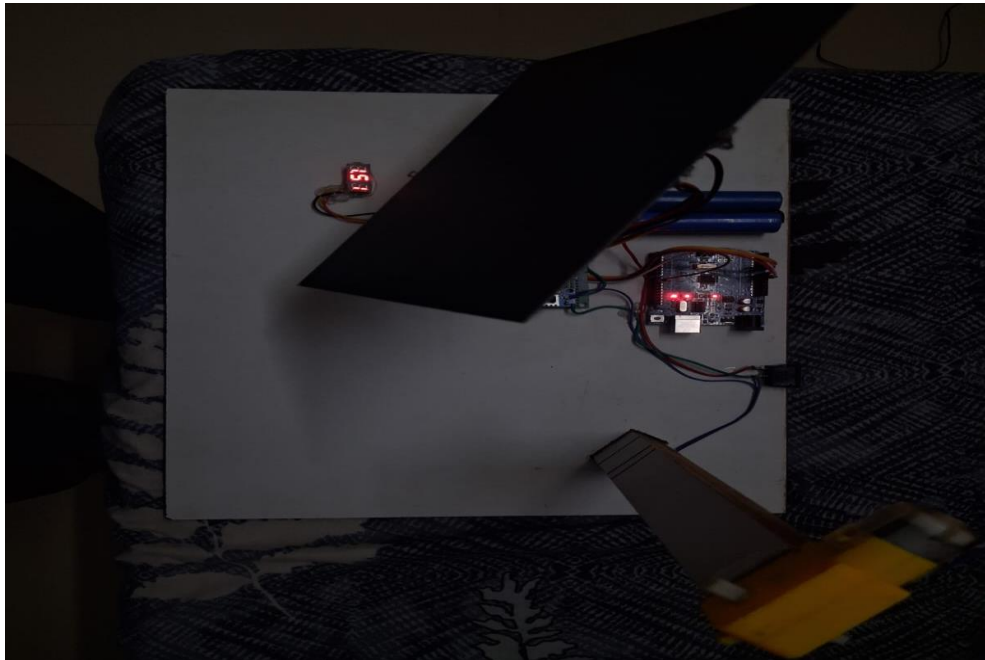

Fig3.-Working of the prototype

VI. RESULTS AND DISCUSSIONS

Such solar panels will produce electricity with maximum efficiency. In accordance with the sun's location, the panel will be able to achieve its alignment. Consequently, electricity generation is linear. Because automated panel operation minimizes human error and allows for regulated tracking, it will make these approaches more accessible. Performance is enhanced as a result. Green energy is aided by the use of non-renewable resources.



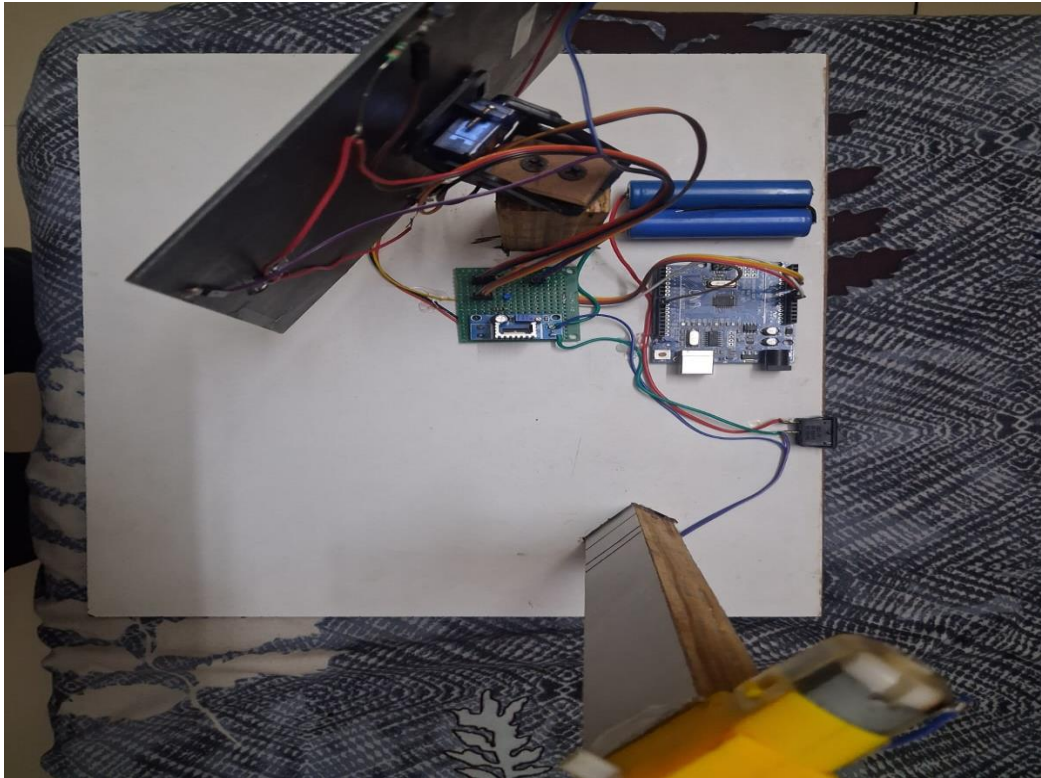

Fig. Model of the project.

V. FUTURE SCOPE

Because sun-tracking solar panels can monitor the sun's course throughout the day to maximize the amount of sunlight they receive, they have the potential to greatly boost the efficiency of solar energy systems. Sun-tracking solar panels have a bright future. as more and more research is being conducted to improve their design and functionality, making them more efficient, cost-effective, and easier to use. With the increasing demand for renewable energy sources, sun-tracking solar panels are expected to become more popular in the future, and could play crucial role in fulfilling the energy needs of the world in a sustainable way. Innovation is to be made in the current panel and a dual-axis tracking panel can be designed which will perform in a multidimensional workspace

VI. CONCLUSION

By improving solar panel efficiency, the project makes it possible to gather as much energy as possible without losing any. In a similar vein, the experiment demonstrates how software maximizes output by setting the panel to its highest intensity. Self-adjusting solar panels are proven useful as we just need to place them in ample sunlight and rest it works efficiently. Hence, the tracking systems demand more research as it proves to be beneficial in agriculture as well as for power generation in industries as well as in residential areas. It is cost-effective as well as environmental-friendly



REFERENCES

- [1] B. Jayalakshmi, V. Anjali, A. P. Karthik, K. Nibin, S. Lal S. and A. Rahm ath ulla h, "Microcontroller based Automatic Sun Tracking Solar Panel," 2020 Fourth International Conference on I-SMAC (IoT in Social, Mobile, Analytics and Cloud) (I-SMAC), Palladam, India, 2020, pp. 1097-1099, doi: 10.1109/I-SMAC49090.2020.9243494
- [2] Mehdi, Ghazanfar, et al. "Design and fabrication of automatic single axis solar tracker for solar panel." 2019 2nd International Conference on Computing, Mathematics and Engineering Technologies (iCoMET). IEEE, 2019.
- [3] A. Sharma, V. Vaidya and K. Jamuna, "Design of an automatic solar tracking controller: Solar tracking controller," 2017 International Conference on Power and Embedded Drive Control (ICPEDC), Chennai, India, 2017, pp. 505-510, doi: 10.1109/ICPEDC.2017.8081141.
- [4] Asiabanpour, B., Almusaied, Z., Aslan, S. et al. Fixed versus sun tracking solar panels: an economic analysis. *Clean Techn Environ Policy* 19, 1195–1203 (2017).
- [5] Moradi, Hadis, Amir Abtahi, and Roger Messenger. "Annual performance comparison between tracking and fixed photovoltaic arrays." 2016 IEEE 43rd Photovoltaic Specialists Conference (PVSC). IEEE, 2016.
- [6] Deekshith K, Dhruva Aravind, Nagaraju H, Bhaskar Reddy, "Solar tracking system," *International Journal of Scientific & Engineering Research*, Volume 6, Issue 9, September-2015 994 ISSN 2229-5518.
- [7] Rinaldi, Rizal, et al. "Design of open loop single axis solar tracker system." *IOP Conference Series: Materials Science and Engineering*. Vol. 982. No. 1. IOP Publishing, 2020.
- [8] Soumya Das, Pradip Sadhu, Nitai Pal, Suprotim Mukherjee, "Single Axis Automatic Solar Tracking System Using Microcontroller," *TELKOMNIKA Indonesian Journal of Electrical Engineering* 12(12), 8028-8032, 2014.
- [9] Rad, Mohammad Amin Vaziri, et al. "A comprehensive study of techno-economic and environmental features of different solar tracking systems for residential photovoltaic installations." *Renewable and Sustainable Energy Reviews* 129 (2020): 109923.
- [10] M. Saeedi and R. Effatnejad, "A New Design of Dual-Axis Solar Tracking System With LDR Sensors by Using the Wheatstone Bridge Circuit," in *IEEE Sensors Journal*, vol. 21, no. 13, pp. 14915-14922, 1 July1, 2021, doi: 10.1109/JSEN.2021.3072876.
- [11] Ponniran, Asmarashid, Ammar Hashim, and Handy Ali Munir. "A design of single axis sun tracking system." 2011 5th International Power Engineering and Optimization Conference. IEEE, 2011.
- [12] Sefa, Ibrahim, Mehmet Demirtas, and Ilhami Çolak. "Application of one-axis sun tracking system." *Energy conversion and Management* 50.11 (2009): 2709-2718.
- [13] Racharla, Suneetha, and K. Rajan. "Solar tracking system—a review." *International journal of sustainable engineering* 10.2 (2017): 72-81.