



# HYBRID POWER GENERATION BY SOLAR+ WIND

<sup>1</sup>Mr. Gaikwad S.K., <sup>2</sup>Shubham Gajanan Aarakh, <sup>3</sup>Pratik Ramkrushna Shitre, <sup>4</sup>Sumit Suhas Shendage,  
<sup>5</sup>Vedant Shyam Murumkar,

<sup>1</sup>Asst. Prof. Electrical Dept. JSPM's Bhivrabai Sawant polytechnic, Wagholi

<sup>2</sup>UG Scholar, Electrical Dept. JSPM's Bhivrabai Sawant polytechnic, Wagholi

<sup>3</sup>UG Scholar, Electrical Dept. JSPM's Bhivrabai Sawant polytechnic, Wagholi

<sup>4</sup>UG Scholar, Electrical Dept. JSPM's Bhivrabai Sawant polytechnic, Wagholi

<sup>5</sup>UG Scholar, Electrical Dept. JSPM's Bhivrabai Sawant polytechnic, Wagholi

**ABSTRACT** - Clean and renewable power generation techniques are now required due to the growing demand for electrical energy and the depletion of traditional energy sources. In order to produce consistent and dependable electricity, this research proposes a hybrid power generation system that combines wind and sun photovoltaic energy. A charge controller is used to mix the energy from both sources, which is then stored in batteries for continuous delivery.

The suggested approach lessens reliance on fossil fuels while increasing sustainability, efficiency, and dependability. An application of a wind-solar hybrid power generating system controlled by a single-chip microcomputer is covered in this study, along with the design of the system's operation scheme. The experimental findings demonstrate that, in comparison to the traditional design, this type of power generation system and its operating scheme are superior.

An average solar irradiance of 5.68KW/m<sup>2</sup> /day and wind speed of 12.9mph is available over the parts of Kerala. The average temperature range in the parts of Kerala is 28°C since it is located in between Tropic of Cancer and Equator. Standalone models for a PV and wind is also simulated. The hybrid model consists of solar panels, (P&O) MPPT, boost converter, inverter, wind turbine, PMSG generator all connected to a grid. Under different irradiance and temperature conditions the PV model is simulated, and output is observed. The hybrid model is simulated, and the Matlab results are analyzed

## I. INTRODUCTION

The demand for electrical energy is rising quickly as a result of both home and industrial expansion. Traditional sources, like coal and diesel, are scarce and pollute the environment. When used separately, renewable energy sources like wind and solar are plentiful and clean, but they are sporadic. A hybrid system can guarantee continuous generation and improved use of the resources that are available by integrating both sources.

The UAV's conventional power source is its internal batteries. The UAV's endurance time and effective flying are limited since it must conclude its flight mission before the batteries run out in order to guarantee that it takes off and lands inside the monitoring area. An excessive number of batteries will



make aircraft, which reduces the UAV's flying efficiency. Therefore, there is a wide market potential for the design of a simple structure, smooth operation, high efficiency of work and operation, energy conservation and environmental protection, and a quick and easy UAV method utilized to solve many weaknesses in the current technology.

### **1.1 Problem Identification**

The conventional energy sources are being depleted and causing severe negative impacts to the ecosystem thus exploiting the future needs. Renewable energy plays a vital role in sustaining these conventional sources. The renewable energy is abundantly available in the nature but without proper control and incorporation these resources cannot be used for power generation. The nonconventional energy sources are based on the weather conditions. Depending upon a single source of energy for power generation causes several limitations in the performances. Main drawback on depending on a single source of energy is the unstable operation caused due to inaccessibility and climatic variations. Solar and wind has high potential and is available in plenty in the atmosphere but due to variation in weather, this hybrid power generation system faces the issue of improper and unstable utilization of the accessible sources. Other challenge faced in integrating a renewable energy source for power generation is power quality issues like voltage sag, voltage dip, harmonics, power fluctuations, transients etc. (Aggarwal and Nijhawan 2016)

### **1.2 Objective of the Paper**

The primary objective of the project is to utilize the available renewable energy in the nature without causing any harmful effects to the human lives and environment. The main objectives of the project include: i. To conduct a feasible analysis of the solar and wind availability in nature to develop an alternative solution to the existing power generation system. ii. To develop a grid connected hybrid solar and wind model using a Matlab/Simulink. iii. To utilize the maximum available energy for the power generation using controlling techniques.

## II. OVERALL SCHEME DESIGN

Solar panels, a wind turbine, a charge controller, a battery bank, an inverter, and a load make up the hybrid system. While wind turbines generate energy when wind is available, solar panels generate power during the day. The battery is charged by both sources via a controller that controls the voltage and current levels.

A UAV with a wind-solar complementary power generating system—which consists of a battery pack mounted to the UAV—is the subject of the utility model.

The Wires are used to connect the battery pack to a power adapter, which is then connected to solar panels and wind power producing equipment, respectively [1].

To produce power, photovoltaic or photothermal conversion solar panels are utilized. 12V solar panels are used by each solar panel. Windmill blades power the wind power generation apparatus, which produces electricity. Every wind power generator uses a 12V wind power generator. Three-second smart lithium batteries were used. The upper lighting position of the structure is equipped with solar panels. either the bottom portion of the power wing or the upper portion of the UAV frame [2].

Installing solar panels on the upper portion of the UAV frame, the casing, the power wing, or the horizontal tail wing is the general operating procedure. To extend the endurance of the UAV, wind power generation devices can be installed on the upper portion of the UAV frame or the lower portion of the power wing. The energy produced by the solar panels and wind power generation devices is then fed back to the storage battery via the power adapter.

## III. 12V POWER ADAPTER DESIGN

The UAV's power supply has unique chargers, such as input DC 15V/800mA and output DC 11.1V/800mA, thus adding a 12V power adapter is all that is required for the wind-solar complementary power generation. To minimize the weight, a straightforward adaptor is selected. The following is the schematic diagram: Design of the Main Circuit

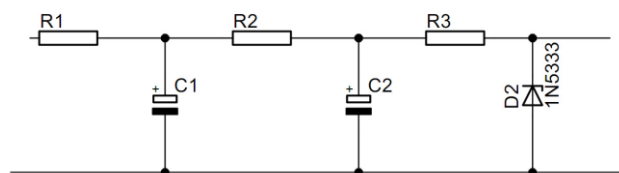

**Fig. 1.** Principle diagram of main circuit Control Circuit Design



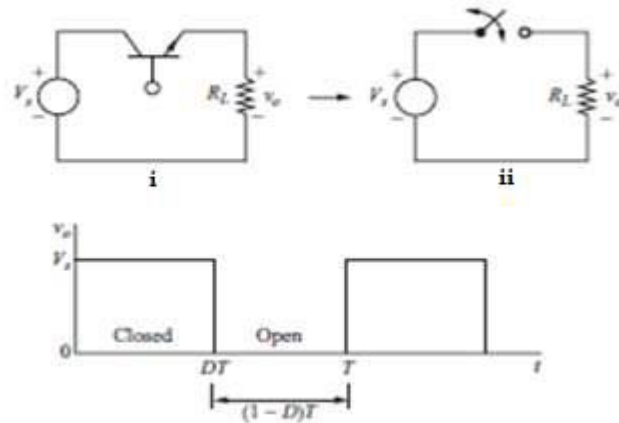

Fig 3.- Closed and Open Mode of a Switch(Hart 2010)

## 4.2 Boost Converter

The boost converter is also termed as step up converter. In a DC-DC boost converter the output voltage will be higher than the input voltage. In a transformer the voltage is stepped up from low level voltage to high level which is same as the step up in converters. With the law of conversion of energy, the input power( $P_{in}$ ) must be equal to output power( $P_{out}$ ). Therefore, the output voltage from the boost converters will be higher than input voltage which results in a decrease in the output current whereas the input current will be higher.(Hart 2010, Ecetutorials.com 2018)

## V. HARDWARE REQUIREMENTS & SOFTWARE REQUIREMENTS

- Solar Panel
- Wind Turbine Generator
- Charge Controller
- Battery Bank
- Inverter
- Microcontroller (optional for monitoring)
- Arduino IDE
- Embedded C/C++
- Monitoring dashboard (optional IoT platform)

## VII. CONCLUSION

The hybrid solar-wind power generation system provides an efficient and reliable solution for sustainable energy production. By combining two renewable sources, the system ensures continuous power, reduces fossil fuel dependence, and supports green energy initiatives.

In summary, the UAV wind-solar hybrid power generation system based on the AT89s51 single-chip microcomputer designed as the main control system. The system operation scheme has greatly improved the system function and leaving room for the future development of the traditional 220V charging. At the same time, the design minimizes the size and reduces the weight of the drone, enhancing the flexibility of the drone and meeting the basic needs of the drone power control. This design has a good application prospect. Generation of power from single source of renewable energy cannot meet the load demands therefore, hybrid PV-Wind model is proposed to compensate the effects of environmental factors and climatic variations of the resources affecting the continuous operation of power generation. For efficient tracking of solar energy Perturb and Observe(P&O) MPPT technique is used and a boost converter is used to eliminate fluctuations at the Inverter to convert to AC power. Wind energy system with permanent magnet synchronous generator produces sinusoidal AC power. The two energy sources are combined to power the grid to meet the demands.

## REFERENCES

1. Deere & Company; Researchers Submit Patent Application, "Unmanned Aerial Vehicle (Uav)- Assisted Worksite Data Acquisition", for Approval (USPTO 20190114847)[J]. Computers, Networks & Communications,2019.
2. Sahil Vashisht,Sushma Jain. Software-defined network-enabled opportunistic offloading and charging scheme in multi-unmanned aerial vehicle ecosystem[J]. International Journal of Communication Systems,2019,32(8).
3. Alejandro Gómez-Pazo, Augusto Pérez-Alberti, Alan Trenhaile. Recording inter-annual changes on a boulder beach in Galicia, NW Spain using an unmanned aerial vehicle[J]. Earth Surface Processes and Landforms,2019,44(5).
4. Catherine E. Waite, Geertje M. F. Heijden, Richard Field, Doreen S. Boyd. A view from above: Unmanned aerial vehicles ( UAV s) provide a new tool for assessing liana infestation in tropical forest canopies[J]. Journal of Applied Ecology,2019,56(4).
5. Muhammad Ushaq, Fang Jian Cheng, Ali Jamshaid. A Fault Tolerant SINS/GPS/CNS Integrated Navigation Scheme Realized through Federated Kalman Filter[J]. Applied Mechanics and Materials,2013,2466(332).