

RENEWABLE ENERGY SOURCES BASED ELECTRIC VEHICLE CHARGING CONSIDERING RADIO FREQUENCY IDENTIFICATION

¹Ranmale Suyog Vinayak, ²Jadhav Krushna, ³Pol Yash Shashikant, ⁴Sonavane Rahul Dnyaneshwar,
⁵Bagul Prashant Shivaji ⁶Pawar Atul Bhausaheb, ⁷Dr. P.C. Tapre

¹UG Scholar, Department of Electrical Engineering, SND COE & RC, Yeola

²UG Scholar, Department of Electrical Engineering, SND COE & RC, Yeola

³UG Scholar, Department of Electrical Engineering, SND COE & RC, Yeola

⁴UG Scholar, Department of Electrical Engineering, SND COE & RC, Yeola

⁵UG Scholar, Department of Electrical Engineering, SND COE & RC, Yeola

⁶Asst. Prof, Department of Electrical Engineering, SND COE & RC, Yeola

⁷HOD, Department of Electrical Engineering, SND COE & RC, Yeola

ABSTRACT: An electric vehicle is a new and upcoming technology in the transportation and power field that offers numerous advantages for the environment and economy.

This paper offers a thorough analysis and assessment of several kinds of electric cars as well as the accessories that go along with them, such as charging stations and battery chargers. The electric range, battery size, and charger power of commercial and prototype electric vehicles are compared. and charging time. The various types of charging stations and standards used for charging electric vehicles have been outlined and the impact of electric vehicle charging on utility distribution systems is also discussed.

Keywords: Battery charger, charging station, electric vehicle, standards.

I. INTRODUCTION

1.1 Background

Equipment that links an electric vehicle (EV) to an electrical source in order to refuel plug-in hybrids, electric automobiles, and neighbourhood EVs is known as an electric vehicle charging station. While some charging stations are more simple, others include more sophisticated features like smart metering, cellphone capability, and network access. Electric utility providers and private organisations provide charging stations in municipal parking lots and retail shopping centres. Charging stations are also known as electric vehicle supply equipment (EVSE).

Special connectors are available at these stations that conform to the variety of electric charging connector standards. Fees for using EVSE vary from monthly or yearly flat rates to per-kWh to hourly rates. Charging stations can be free and are usually subsidized by the local government. Different types of EVSE provide different speeds of charging. Level 1 charging stations use a 120 volt (V), alternating-current (AC) plug and require a dedicated circuit, offering about 5 miles of range for every hour of charging. Level 2 stations charge through a 240V, AC plug and require home charging or public charging equipment to be installed. Level 2 stations provide 10 to 20 miles

of range for every hour of charging. Level 2 chargers are the most common and charge at approximately the same rate as a home system. Level 3 chargers are also known as DC fast chargers. Level 3 uses a 480V, direct-current (DC) plug.

Theme

Energy in the form of electricity plays a very important role in our day to day life. Electricity is one of the greatest wonders of science. Next to man, it is the most important and revolutionary creation in this world of ours. The gradual but excessive use of electricity has come to bring about remarkable changes in industry. Computers as calculators sum up totals and make other calculations with the utmost accuracy. Newspapers and books are printed in millions overnight. There is not a single phase of human life that is not indebted to electricity for its progress. The modern age has, therefore, been truly called the “age of electricity.”

II. LITERATURE REVIEW

In recent years, Electric vehicles (EV) are receiving significant attention as an environmental-sustainable and cost-effective substitute of vehicles with internal combustion engine (ICE), for the solution of the dependence from fossil fuels and for the saving of Green-House Gasses (GHG) emission. In this framework, different standards for EVs charging systems have been explored by several organizations around the world. For defining them, organizations consider the safety, the reliability, the durability, the rated power and the cost of the different charging methods. The charging equipment for EVs plays a critical role in their development, grid integration and daily use: a charging station generally includes charge cord, charge stand, attachment plug, and power outlet and vehicle connector and protection system. The configuration of the charging station can vary from Country to Country depending on frequency, voltage, electrical grid connection and standards. In any case, charging time and lifetime of an EV's battery are linked to the characteristics of the charger that first must guarantee a suitable charge of the battery. Then a good charger should be efficient and reliable, with high power density, low cost and low volume and weight. After a complete overview on different types of EV charging stations and a comparison between the related European and American Standards, the paper includes a summary on possible types of Energy Storage Systems (ESSs) and possible layout of charging stations including them. ESSs can become fundamental for the integration in smart grids of EV fast charging stations of the last generation: in this case the storage can have peak shaving and power quality functions and also to make the charge time shorter. From this brief analysis, it is possible to conclude that a good ESS for the coupling fast EV charging stations can be considered a system including batteries and ultra-capacitors: the first are suitable for their high energy densities and the second for their high power density. About the integration of ESSs, another important issue investigated is the way of integration in terms of electrical scheme. Two possibilities have been found in literature, based on an AC-bus configuration and DC-bus configuration. The AC-bus scheme is generally preferred, because the AC components have well defined standards, and AC technologies and products are already available in the market. However, DC-bus based system provides a more convenient way to integrate renewable energy sources and also higher energy efficiency thanks the inferior number of conversion stages.[1]

III. METHODOLOGY

3.1 Introduction

In our daily lives, energy in the form of electricity is quite crucial. One of science's greatest marvels is electricity. It is the most significant and revolutionary creation in our world, second only to man. The industrial sector has undergone significant transformations due to the steady yet excessive consumption of power. Calculators on computers add up totals and perform various computations with the utmost accuracy. Newspapers and books are printed in millions overnight. There is not a single phase of human life that is not indebted to electricity for its progress. The modern age has, therefore, been truly called the “age of electricity.” The infrastructure element that provides the crucial link between an Electric Vehicle (EV) with a depleted battery and the electrical source that will recharge those batteries is the Electric Vehicle Supply Equipment or EVSE.

3.2 System Architecture

SOLAR PANEL

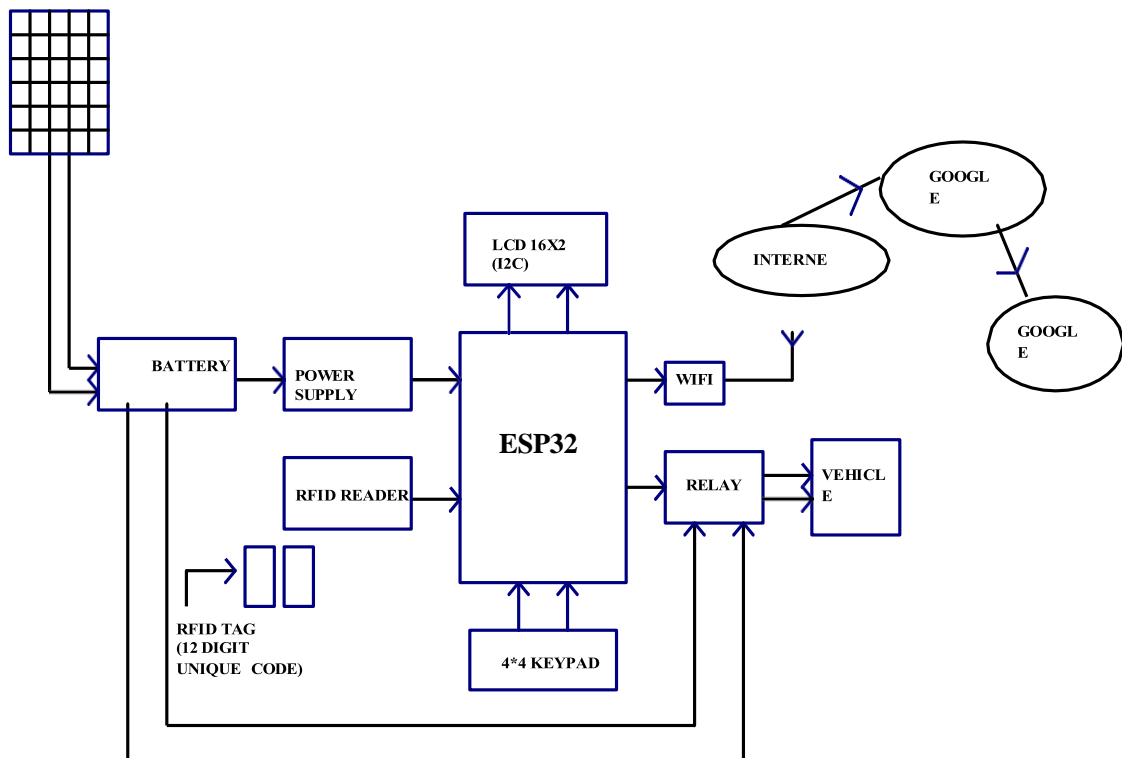

Figure 1: Block Diagram

3.3 Working

The prototype of EV charging station is proposed such that it uses the renewable energy (Solar Energy). An electrical vehicle battery recharging system composed of photovoltaic solar panel connected to the electrical power grid. With the help of Solar panel, energy will be stored into the battery. Here we are providing RFID card to each customer with which customer can access petrol at the charging stations. Before using this card we have to recharge it like a prepaid card. Whenever we want to charge the vehicle battery, just we have to enter required amount and place the RFID

card near the RFID reader. Then microcontroller reads the data from the RFID reader and performs the action according to

the customer. This system also provides the security for the customers for vehicle battery charging at the EV charging stations by avoiding the involvement of human beings, so to avoid the risk of carrying money every time and charge the battery on hours basis as well whenever required. All the data is display on OLED and saved in Google sheet. When vehicle is parked at the charging station, vehicle battery will be charged by charging station battery.

3.4 Software Requirements

Table 3.1: Software Requirements

Sr. No	Software Name	Description
1	Arduino IDE	For programming on ESP-32 Microcontroller
2	OrCAD	To designing purpose
3	Altium	For PCB designing
4	Proteus	For simulation purpose

3.5 Hardware Requirements

Table 3.2: Hardware Requirements

Sr. No	Hardware Name	Description
1	ESP-32 Microcontroller	It will use as microcontroller
2	RFID Tags	It will store the information along with tags
3	Solar Panel	It will store the energy of Solar
4	RFID Reader	To read the information provided by RFID Tags
5	LCD with I2C module	To display the result
6	Keypad	For enrolling the new person with the system

3.6 Flowchart

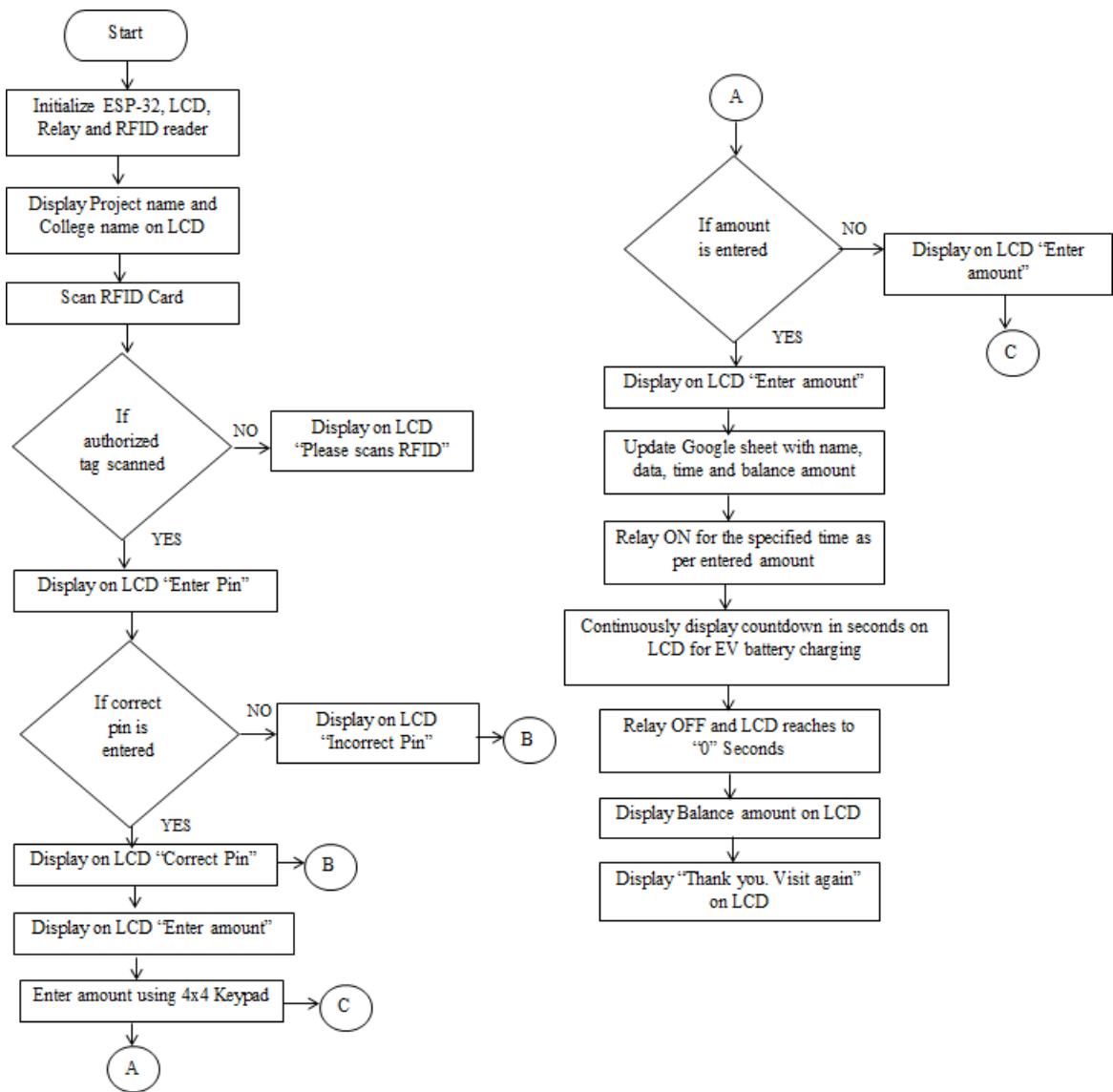

IV. EXPERIMENTAL ANALYSIS

The experimental analysis is based on charging infrastructure, it provides an overview of optimization metrics such as: Minimizing various charging infrastructure cost type, minimizing total travel time, minimizing trip failure, maximizing flow captured, maximizing covered demand, maximizing charging post usage, minimizing number of

charging stations and grid management. The main objectives are to maximizing charging point usage and minimizing the number of charging points, while maximally covering the demand.

The charging station with energy storage has some notable synergies with benefits to both the charger user and operators. The energy storage can buffer and localize solar electricity. The charging system with intelligent energy management can localize power electricity for energy vehicle charging and eliminate the energy vehicle charging power demand from the grid and shift battery reloading into off peak period if needed. The power electricity, energy vehicle charging

load, the grid electricity consumption and the electricity fed back to the grid are integrated to evaluate the energy between the system and the utility grid.

V. RESULTS AND DISCUSSION

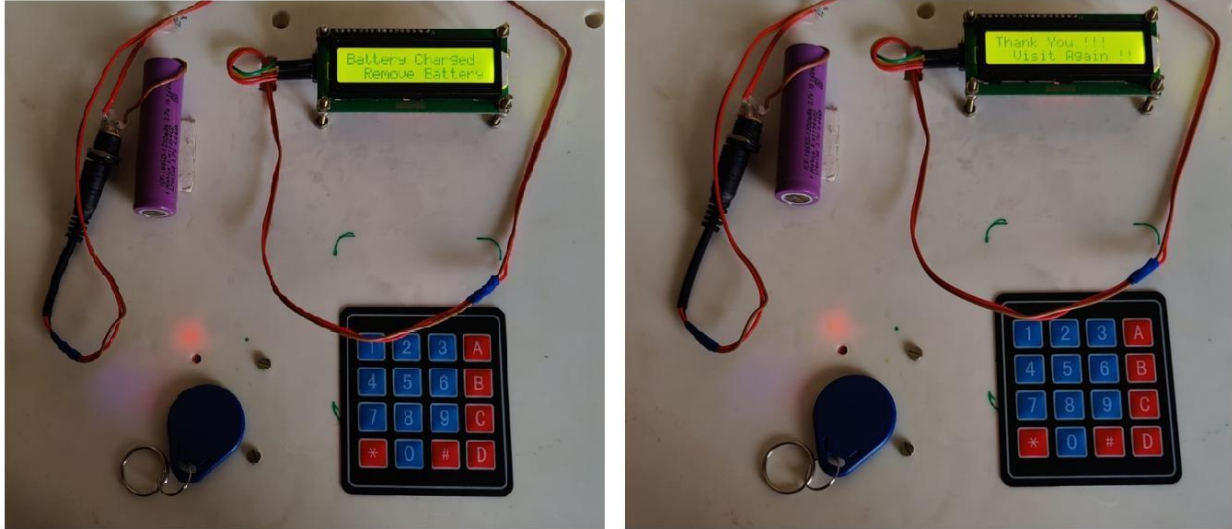

When car charging completely then system automatically give notification that unplugged the charger

VI. CONCLUSION

The prototype of EV charging station with renewable energy source is successfully implemented. The project shows how we can have the accounting facility for EV charging station with Google sheets. The usage of microcontroller with RFID module helps the accounting process for smoother operation. The take away part of the project is microcontroller programming, power supply design and the PCB design. The operation of the opto-coupler in the high and low voltage separation can be easily understood by this process. Hence using the regular components, the prototype of EV charging station is implemented through this project.

REFERENCES

- [1] Maria Carmen Falvo, Danilo Sbordone and I. Safak Bayram, Michael Devetsikiotis, "EV Charging Stations and Modes: International Standards", 2014 International Symposium on Power Electronics, Electrical Drives, Automation and Motion.
- [2] Qin Yan, Bei Zhang, Mladen Kezunovic, "Optimized Operational Cost Reduction for an EV Charging Station Integrated with Battery Energy Storage and PV generation", IEEE Transactions on Smart Grid (Volume: 10, Issue: 2, March 2019)
- [3]
- [4] Michail Vasiladiotis, Alfred Rufer, "A Modular Multiport Power Electronic Transformer with Integrated Split Battery Energy Storage for Versatile Ultra-Fast EV Charging Stations", IEEE